

Spare parts catalog for "D DA - RD"

To avoid errors, when ordering please specify:

- Complete type of hoist
- Date of manufacture and serial number
- Spare part code
- Spare part designation
- Additional information

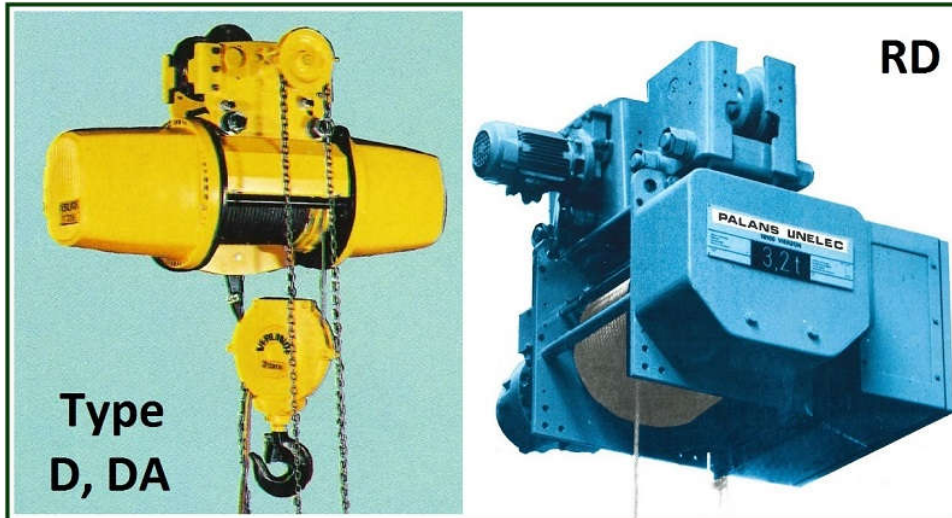

0) HOIST DESCRIPTION

1) MOTOR / HOISTING GEARBOX D-DA & RD

- 1.1) Eurobloc D-DA
- 1.2) RD

2) COVER / SWL PLATE

- 2.1) Eurobloc D-DA
- 2.2) RD

3) HOISTING GEARBOX

- 3.1) Eurobloc D-DA
- 3.2) RD

4) BRAKE D & DA

- 4.1) Manual brake
- 4.2) Automatic brake

5) BRAKE FOR RD

- 5.1) FCO - FCM - FCL brake for RD
- 5.2) GHUC brake for RD

6) DRUM / COUPLING

- 6.1) EUROBLOC D & DA
- 6.2) RD

7) OVERLOAD LIMITER / CROSSHEAD / FIXED POINT

8) RETURN

9) LOW HEADROOM FRAME

10) NORMAL HEADROOM FRAME

11) ROPE GUIDE / LIMIT SWITCH

- 11.1) EUROBLOC D & DA
- 11.2) RD

12) HOOK BLOCK - 1 FALL

- 12.1) CABLE Ø 11 mm
- 12.2) CABLE Ø 12 mm

13) HOOK BLOCK - 2 FALLS

14) HOOK BLOCK - 4 FALLS

15) HOOK BLOCK - 6 FALLS

16) MONORAIL TROLLEY TYPE

- 16.1) EUROBLOC D DA
- 16.2) RD

17) TROLLEY SETTING TABLE

18) SWIVELLING TROLLEY - TYPE II 78

19) DOUBLE GIRDER TROLLEY

20) BISSEL TROLLEY (HPR72) FOR D TYPE ONLY

21) NA TROLLEY FOR D TYPE ONLY

22) GEAR AND MOTORGear

- 22.1) DC1
- 22.2) DC2
- 22.3) DC3
- 22.4) DC4

23) ELECTRIC TRAVEL AND CHAIN TRAVEL

24) HOIST ROPE

- 24.1) Precut rope

25) ELECTRICAL EQUIPMENT

0) Hoist description

GROUPE
EUROBLOC DA

		la	lb	II	III																
		Vitesse de levée en m/min - Cases encadrées appareils mouflés																			
Moteurs	Repères	DA16	DA8	DA20	DA10	DA25	DA12	DA32	DA16	DA40	DA20	DA50	DA25	DA63	DA40	DA100	DA125	DA150			
1 vitesse 3 Kw 1500 l/min	201 251 301 501	9,7	19,4	8,1	16,2			5,4	10,9			3,25		2,7							
1 vitesse 4,4 Kw 1500 l/min	201 251 301					9,7	19,4	8	16,2			4,8		4	3,2	2,7					
1 vitesse 7,4 Kw 1500 l/min	201 251									9,7	19,4	8	16,2		4,8	4	3,2	2,7			
2 vitesses 3/0,75 Kw 3000/750 l/min	202 252 302 502	9,7/2,4	19,4/4,8	8,1/2	16,2/4			5,4/1,3	10,9/2,7			3,25/0,8		2,7/0,65							
2 vitesses 4,4/1 kW 3000/750 l/min	202 252 302					9,7/2,4	19,4/4,8	8/2	16,2/4			4,8/1,2		4/1	3,2/0,8	2,7/0,65		2,7/0,65			
2 vitesses 7,4/3 Kw 3000/750 l/min	202 252									9,7/2,4	19,4/4,8	8/2	16,2/4		4,8/1,2	4/1	3,2/0,8	2,7/0,65			
Palan suspendu		S	Posé	P																	
Tambour		N																			
Osature		HPN								HPR											
Capacité de charge		1600	4000	5000	8000	1600	4000	5000	8000	1600	4000	5000	8000	1600	4000	5000	8000	12500	15000		
Nature du câble		P	P	P	P	P	P	P	P	A	A	P	P	A	A	P	P	P	P		
Ø câble		11	12	11	12	11	12	11	12	11	12	11	12	11	12	11	12	11	12		
Long câble standard		22,35	22,25	24,5	24,5	22,25	22,25	23	23	26,7	38	38	39	39	37	37	38	38	41,3	41,3	
Hauteur de levée		9	9	4,5	4,5	9	9	4,5	4,5	3	16,5	16,5	8	8	16	16	8	8	5,5	5,5	
Palan mouflé		2/1	2/1	4/1	4/1	2/1	2/1	4/1	4/1	6/1	2/1	2/1	4/1	4/1	2/1	4/1	4/1	6/1	6/1		
Tambour		SL								SSL											
Osature		HPN				HPR				HPN				HPR							
Capacité de charge		1600	4000	5000	8000	1600	4000	5000	8000	12500	1600	4000	5000	8000	12500	1600	4000	5000	8000	12500	15000
Nature du câble		A	A	A	A	A	P	P	P	P	A	A	A	A	P	P	P	P	P	P	
Ø câble		11	12	11	12	11	12	11	12	11	12	11	12	11	12	11	12	11	12	11	12
Long câble standard		54	54	53	53	53	53	59,4	59,4	66	66	65	65	65	65	65	65	68,6	68,6		
Hauteur de levée		24	24	23	23	11,5	11,5	8	8	30	30	29	29	14,5	14,5	10	10	10	10		
Palan mouflé		2/1	2/1	2/1	2/1	4/1	4/1	6/1	6/1	2/1	2/1	2/1	2/1	4/1	4/1	6/1	6/1				
Palans brin direct		1/1	2/2	Suspendu	S	Posé	P	Ap. murale													
Tambour		N																			
Nombre de brins		1/1	2/2	1/1	2/2	1/1	2/2	1/1	2/2	1/1	2/2	1/1	2/2	1/1	2/2	1/1	2/2				
Force		800-1000-1250-1600-2000-2500																			
Nature du câble		A		P		A		P		A		P		A		P					
Ø du câble		11 ou 12		11		11 ou 12		11		11 ou 12		11		11 ou 12		11					
Long câble sur tambour		21,25		22		37		22		53		22		69		22					
Long câble déviateur utile		18		6,7		33		14		48		23		60		27					

		Vitesse de levée en mètres mn - Cases encadrées : appareils mouflés						
Moteurs	Repères	D 15	D 20	D 25	D 30	D 50	D 60	
1 vitesse 4 cv - 1500 T/min	E	201		7,5	15			
		251	9	18				
		301				5	10	
		501						3
1 vitesse 6 cv - 1500 T/min	G	201				7,5	15	3,75
		251				9	18	4,5
2 vitesses 4 cv / 1 cv3000 / 750 T/min	F	202		7,5/1,7	15/3,4			
		252	9/2	18/4				
		302				5/11	10/2,2	
		502						3/0,65
2 vitesses 6 cv / 1,5 cv 3000 / 750 T/min	H	202				7,5/1,7	15/3,4	3,75/0,85
		252				9/2	18/4	4,5/1

Groupe	Type suspendu				4 sorties de câble			
	Type posé				A	B	C	D
TYPE	N	L	N	L	N	L	N	L
Force	1500-2000-2500-3000		5000-6000		750-1000-1250-1500			
Nbre de brins	2		4		1 trait		2 traits	
Hauteur de levée	10		17		5		8	
Ø du câble	10,5 - 11							
Longueur du câble	24		39		24,5		40	
					24		39	
					2 x		2 x	

1) Motor / Hoisting gearbox D-DA & RD

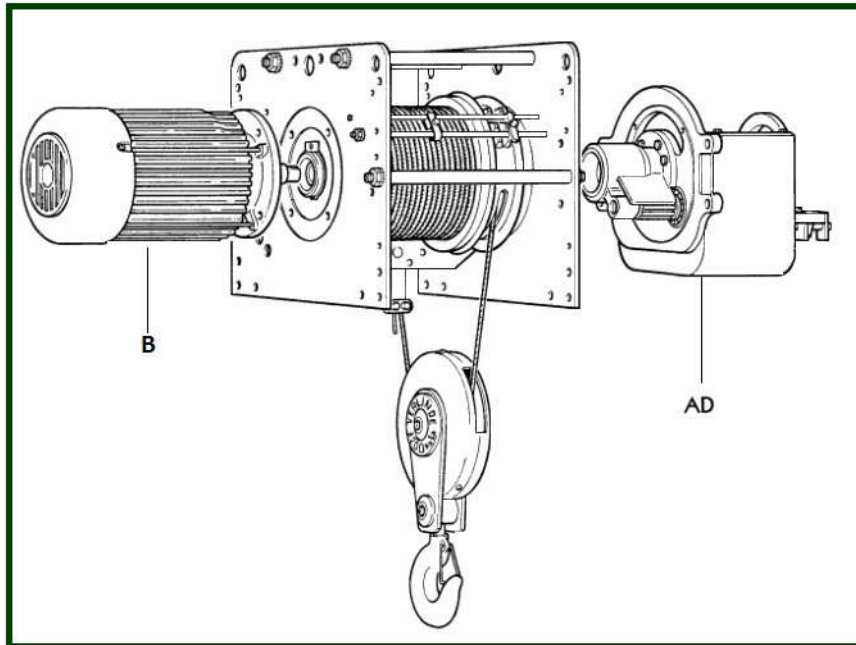

1.1) Eurobloc D-DA

En cas de changement du moteur, une modification doit être effectuée suivant l'instruction disponible ici / In case of motor replacement, a modification must be carried out according to the instruction available here

item	reference	description	observation	Quantity
AD	3254020D	Hoisting gearbox without disc	D201	1
AD	3254024H	Hoisting gearbox without disc	D202	1
AD	3254021E	Hoisting gearbox without disc	D251	1
AD	3254025J	Hoisting gearbox without disc	D252	1
AD	3254022F	Hoisting gearbox without disc	D301	1
AD	3254026K	Hoisting gearbox without disc	D302	1
AD	3254023G	Hoisting gearbox without disc	D501	1
AD	3254027L	Hoisting gearbox without disc	D502	1
AD	3354020Z	Hoisting gearbox without disc	DA201	1
AD	3354024D	Hoisting gearbox without disc	DA202	1
AD	3354021A	Hoisting gearbox without disc	DA251	1
AD	3354025E	Hoisting gearbox without disc	DA252	1
AD	3354022B	Hoisting gearbox without disc	DA301	1
AD	3354026F	Hoisting gearbox without disc	DA302	1
AD	3354023C	Hoisting gearbox without disc	DA501	1
AD	3354027G	Hoisting gearbox without disc	DA502	1
B	7345250T	Hoisting motor 1500t/mn - 200/380V 50Hz - 4,4Kw	b.a : 28x60	1
B	7344230J	Hoisting motor 1500t/mn - 220/380V 50Hz - 3Kw	7345250T	1
B	7346271C	Hoisting motor 1500t/mn - 220/380V 50Hz - 7,5Kw	b.a : 38x80	1
B	7344535R	Hoisting motor 1500t/mn - 240/415V 50Hz - 3Kw	b.a : 28x60	1
B	7345450K	Hoisting motor LS112M2 3000/750t - 220/380V 50Hz - 3/0,75Kw	b.a : 28x60	1
B	7346450X	Hoisting motor LS132m2 3000/750t/mn - 220/380V 50Hz - 4,4/1,1Kw	b.a : 28x60	1
B	7346771W	Hoisting motor LS132M1 1500t/mn - 240/415V 50Hz - 7,5Kw	b.a : 38x80	1
B	7346950R	Hoisting motor LS132M2 3000/750t/mn - 240/415V 50Hz - 4,4/1,1K	b.a : 28x60	1
B	7346480E	Hoisting motor LS132S 3000/750t/mn - 220/380V 50Hz - 7,5/1,8Kw	b.a : 38x80	1

1.2) RD

item	reference	description	observation	Quantity
AD	<u>3354050G</u>	Hoisting gearbox	RD 201 - 8 m/min	1
AD	<u>3354054L</u>	Hoisting gearbox	RD 202 - 8/2 m/min	1
AD	<u>3354051H</u>	Hoisting gearbox	RD 251 - 10 m/min	1
AD	<u>3354055N</u>	Hoisting gearbox	RD 252 - 10/2,5 m/min	1
AD	<u>3354052J</u>	Hoisting gearbox	RD 301 - 5,3 m/min	1
AD	<u>3354056P</u>	Hoisting gearbox	RD 302 - 5,3/1,3 m/min	1
B	<u>3141061500RD</u>	Hoisting motor LS100L2FCO 1500 T/min - 3 kw	Frein / Brake 20V 220/380V	1
B	<u>3141061501RD</u>	Hoisting motor LS112LM2DP 1500 T/min - 7,6 kw	Frein / Brake FCM 20V 220/380V	1
B	<u>3141061510RD</u>	Hoisting motor LS132M1 2/8 3000/750 T/min - 5/1,25 kw	Frein / Brake PFCL 100V	1
B	<u>3141061511RD</u>	Hoisting motor LS132M2 2/8	Frein / Brake PFCL 100V	1

2) Cover / SWL plate

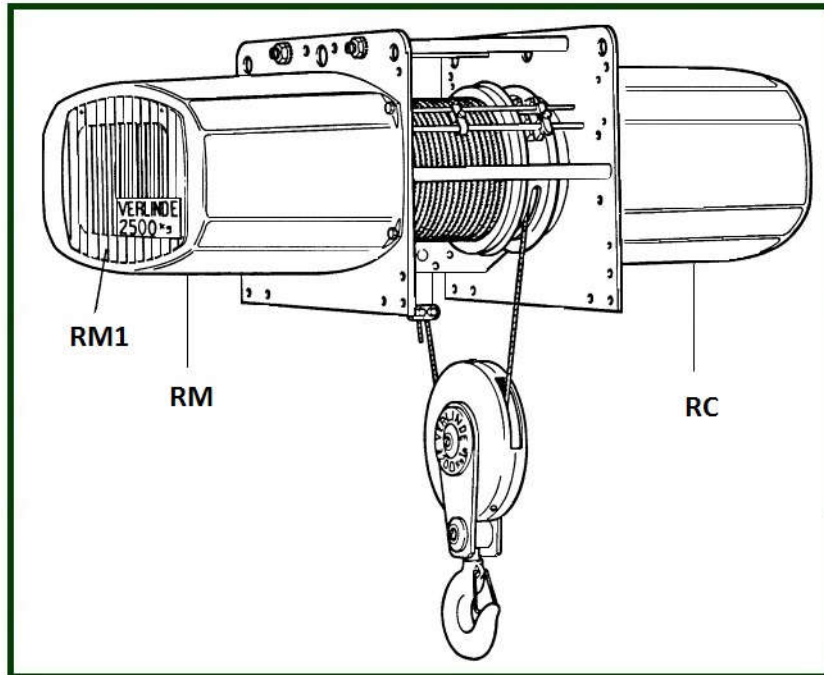

2.1) Eurobloc D-DA

item	reference	description	observation	Quantity
-	<u>7791300E</u>	Cover seal		1
-	<u>KP9AV</u>	Name SWL	VERLINDE	1
-	<u>7257612J</u>	Raymond clip 62607		1
-	<u>5358211T</u>	Spacerring for adjustment	Ep. / Th : 10 -Tambour D (10) - Tambour E (14)	1
-	<u>5358210S</u>	Spacerring for adjustment	Ep. / Th : 25	1
-	<u>KP9A16GB</u>	SWL plate	1,6 Tons	1
-	<u>KP9A25GB</u>	SWL plate	2,5 Tons	1
-	<u>KP9A20GB</u>	SWL plate	2 Tons	1
-	<u>KP9A32GB</u>	SWL plate	3,2 Tons	1
-	<u>KP9A50GB</u>	SWL plate	5 Tons	1
-	<u>KP9A16</u>	SWL plate	1600 Kg	1
-	<u>KP9A20</u>	SWL plate	2000 Kg	1
-	<u>KP9A25</u>	SWL plate	2500 Kg	1
-	<u>KP9A32</u>	SWL plate	3200 Kg	1
-	<u>KP9A50</u>	SWL plate	5000 Kg	1
-	<u>KP9A63</u>	SWL plate	6300 Kg	1
-	<u>KP9A80</u>	SWL plate	8000 Kg	1
-	<u>KP9A100</u>	SWL plate	10000 Kg	1
RC	<u>5258201L</u>	Gearbox cover	D	1
RC	<u>6358201P</u>	Gearbox cover	DA	1
RM1	<u>5258210W</u>	Grill for cover motor end	DA & D	1
RM	<u>5258202N</u>	Motor cover	D	1
RM	<u>5358202H</u>	Motor cover	DA	1

2.2) RD

item	reference	description	observation	Quantity
RC	<u>3141060111RD</u>	Gearbox cover	Fourni sur commande / Provided on request	1

3) Hoisting gearbox

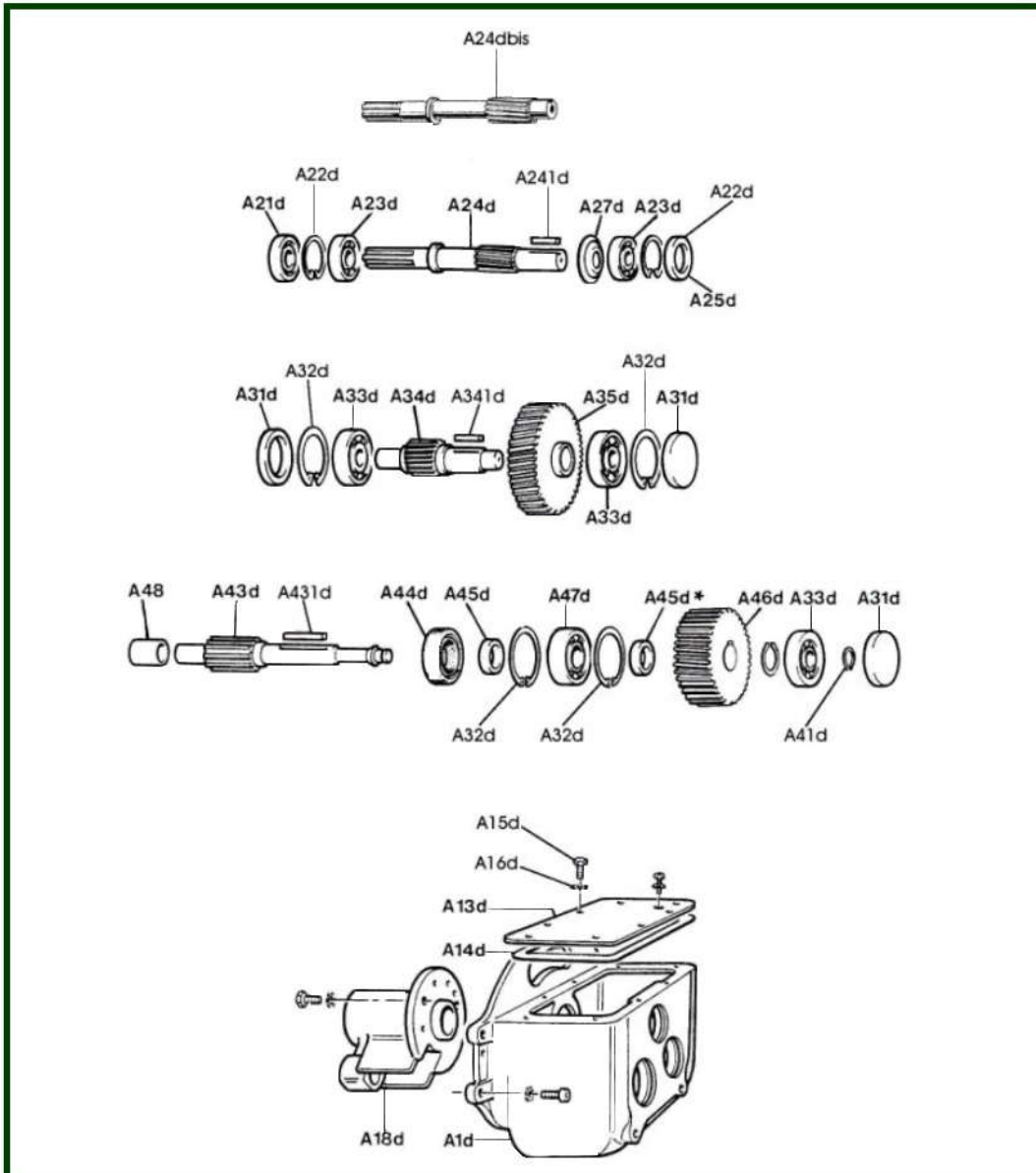

3.1) Eurobloc D-DA

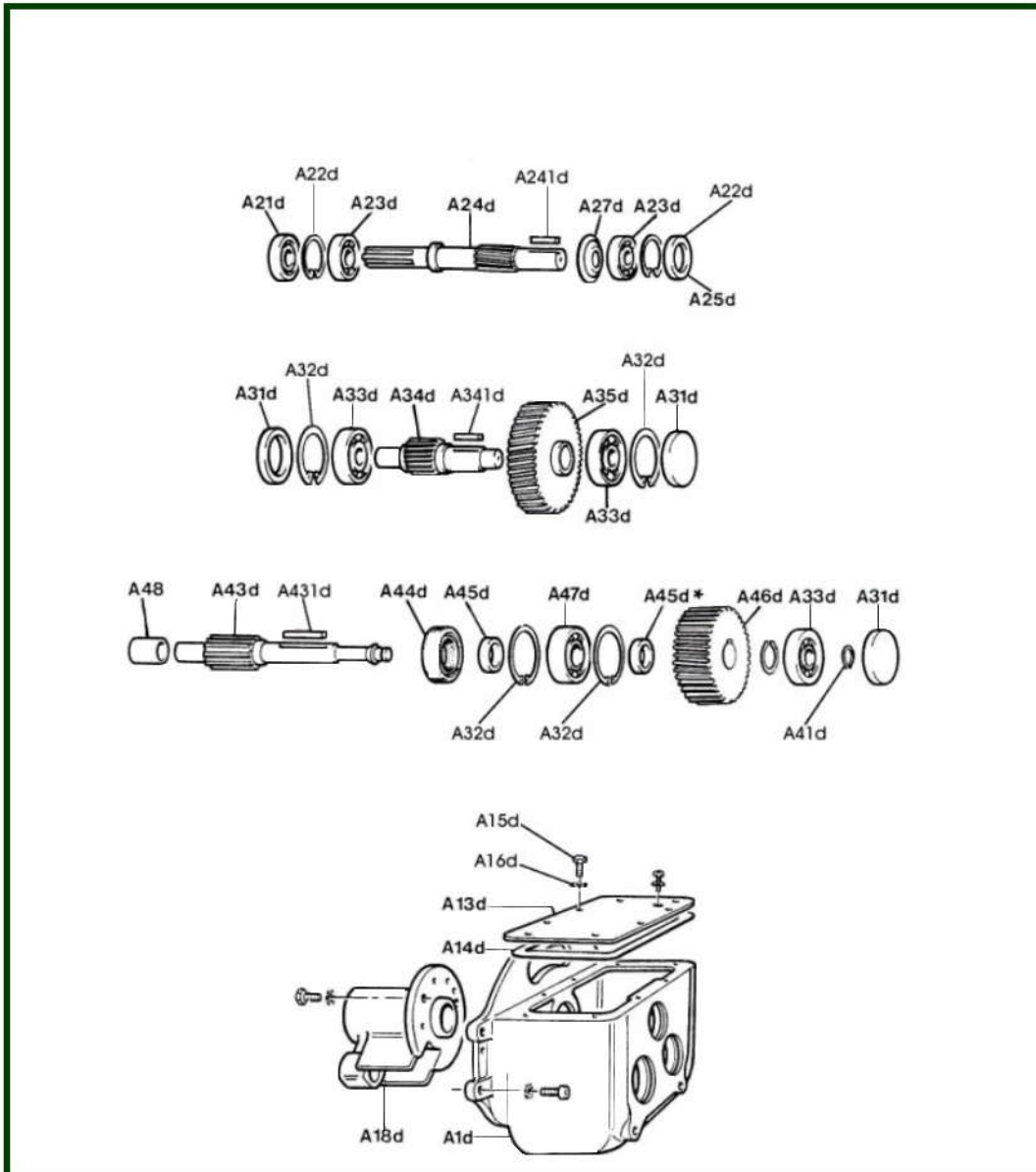

item	reference	description	observation	Quantity
	7238170B	Alu. washer	17 x 13,4 x 1,5	1
	7285050H	Disc washer	11 x 50 x 4	1
	5434106N	Drain plug		1
	8913045T	Grease	1 kg	1
-	A24DD	Bearing and sealing set	Pour/only for A24d	1
A1d	5354102B	Gear case only	DA	1
A13d	5254108N	Gearbox inspection plate		1
A14d	5254102F	Seal		1
A15d	7211353C	HM screw 6 x 16	Liaison câble-tambour / For rope-drum	8
A16d	7232060K	Washer M6	Standard	8
A18d	5354104D	Shaft bracket	DA & RD	1
A21d	7460550U	SIMRIT seal		1
A22d	300079	Circlip - Ø 62	C3-C5- VS2... O (VSX)	1
A23d	7413050P	Bearing		2
A24d	EP304DK333	Motor pinion - 17 teeth	Depuis 1978 /Since 1978 D202-252 - 6 cannelures /6 splines	1
A24d	EP204DK333	Motor pinion - 18 teeth	Depuis 1978 /Since 1978 D202-252 - 6 cannelures /6 splines	1

A24d	<u>EP203DK333</u>	Pinion - 19 teeth	Depuis 1978 /Since 1978 D 201-251-301-501 - 6 cannelures /6 splines	1
A24d	<u>5254203R</u>	Pinion shaft High Speed - 17 teeth	D 302-502 - 6 cannelures /6 splines	1
A24d	<u>5354203L</u>	Pinion shaft High Speed - 17 teeth	DA 302-502	1
A24d	<u>5254202Q</u>	Pinion shaft High Speed - 18 teeth	D 202-252 - 6 cannelures /6 splines	1
A24d	<u>5354202K</u>	Pinion shaft High Speed - 18 teeth	DA 202-252 - 18 cannelures /18 splines	1
A24d	<u>5254201P</u>	Pinion shaft High Speed - 19 teeth	D 201-251-301-501	1
A24d	<u>5354201J</u>	Pinion shaft High Speed - 19 teeth	DA 201-251-301-501 - 18 cannelures /18 splines	1
A25d	<u>7460910K</u>	SIMRIT seal		1
A27d	<u>5254205T</u>	Deflector High Speed		1
A31d	<u>5254316P</u>	Cover		3
A32d	<u>7261080D</u>	Internal circlip - Ø 80		3
A33d	<u>7414050A</u>	Bearing		3
A34d	<u>5354305X</u>	Intermediate pinion - 16 teeth	302	1
A34d	<u>5354304W</u>	Intermediate pinion - 16 teeth	D 301-202 & DA 301-202-502	1
A34d	<u>5354303V</u>	Intermediate pinion - 18 teeth	501-252	1
A34d	<u>5354302U</u>	Intermediate pinion - 22 teeth	201	1
A34d	<u>5354301T</u>	Intermediate pinion - 25 teeth	251	1
A35d	<u>5354210U</u>	Intermediate gear - 92 teeth	D 201-251-501 & DA 201-251-301-501	1
A35d	<u>5354211V</u>	Intermediate gear - 116 teeth	202-252	1
A35d	<u>5354212W</u>	Intermediate gear - 142 teeth	302-502	1
A43d	<u>5354402C</u>	Drive pinion shaft - 17 teeth	DA 201-251-301-302-501-252-502	1
A43d	<u>5254402G</u>	Drive pinion shaft - 17 teeth	D - Après / After 03/77	1
A43d	<u>5254401F</u>	Drive pinion shaft - 17 teeth	D - Avant / Before 03/77	1
A44d	<u>7461030R</u>	SIMRIT seal		1
A45d	<u>5354410L</u>	Spacer collar	35 x 50 x 14	1
A45d	<u>5254410R</u>	Spacer collar	36 x 50 x 16	1
A46d	<u>5354311D</u>	Gear Slow Speed - 65 teeth	251	1
A46d	<u>5354312E</u>	Gear Slow Speed - 68 teeth	201	1
A46d	<u>5354313F</u>	Gear Slow Speed - 72 teeth	501-252	1
A46d	<u>5354314G</u>	Gear Slow Speed - 74 teeth	301-202-502	1
A46d	<u>5354315H</u>	Gear Slow Speed - 85 teeth	302	1
A47d	<u>7418075A</u>	Bearing	D	1
A47d	<u>7424070S</u>	Bearing	DA	1
A48d	<u>7441636K</u>	METAFRAM collar	D	1
A48d	<u>7446501Y</u>	METAFRAM collar	DA & RD	1
A241d	<u>7281085Y</u>	Cotter pin	8 x 7 x 50	1
A431d	<u>7281114E</u>	Cotter pin 10 x 8 x 60		2

3.2) RD

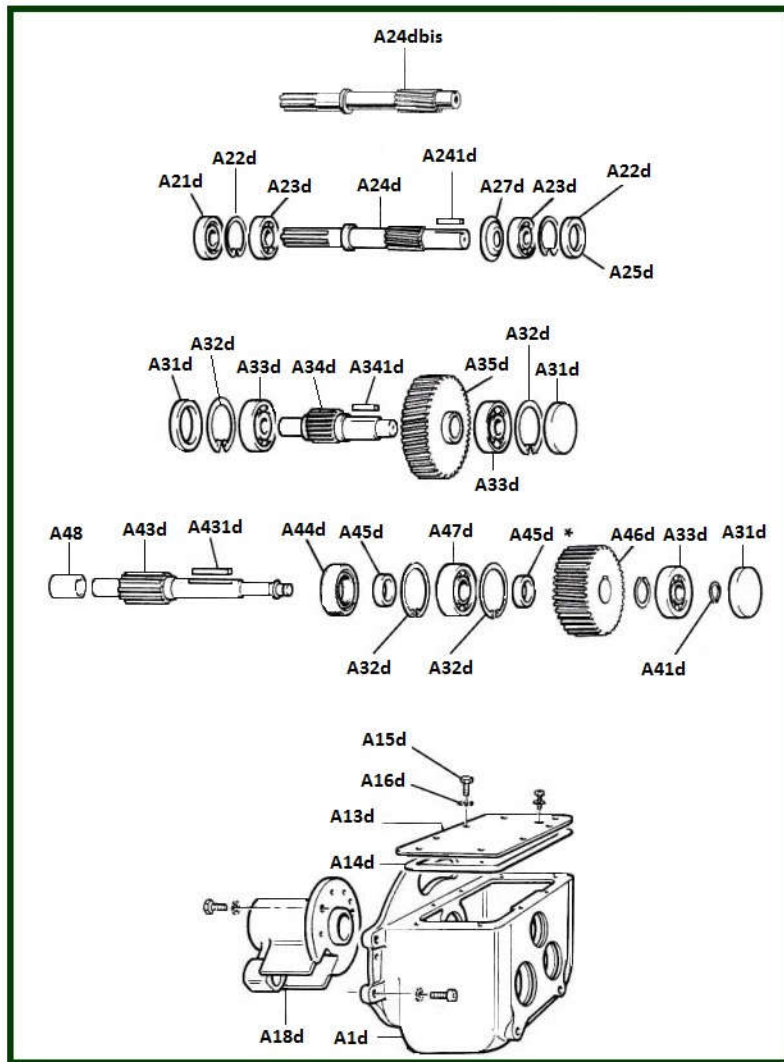

item	reference	description	observation	Quantity
	7238170B	Alu. washer	17 x 13,4 x 1,5	1
	A24DD	Bearing and sealing set	Pour/only for A24d	1
	7285050H	Disc washer	11 x 50 x 4	1
	5434106N	Drain plug		1
	8913045T	Grease	1 kg	1
A1d	5354102B	Gear case only	DA	1
A13d	5254108N	Gearbox inspection plate		1
A14d	5254102F	Seal		1
A15d	7211353C	HM screw 6 x 16	Liaison câble-tambour / For rope-drum	8
A16d	7232060K	Washer M6	Standard	8
A18d	5354104D	Shaft bracket	DA & RD	1
A21d	7460550U	SIMRIT seal		1
A22d	300079	Circlip - Ø 62	C3-C5- VS2... O (VSX)	1
A23d	7413050P	Bearing		2
A24dbis	5354292H	High speed pinion - 17 teeth	302	1
A24dbis	5354293J	High speed pinion - 18 teeth	202 - 252	1
A24dbis	5354291G	High speed pinion - 19 teeth	201 - 251 - 301	1
A25d	7460910K	SIMRIT seal		1
A27d	5254205T	Deflector High Speed		1
A31d	5254316P	Cover		3
A32d	7261080D	Internal circlip - Ø 80		3

A33d	7414050A	Bearing		3
A34d	5354305X	Intermediate pinion - 16 teeth	302	2
A34d	5354304W	Intermediate pinion - 16 teeth	D 301-202 & DA 301-202-502	1
A34d	5354303V	Intermediate pinion - 18 teeth	501-252	1
A34d	5354302U	Intermediate pinion - 22 teeth	201	1
A34d	5354301T	Intermediate pinion - 25 teeth	251	1
A35d	5354210U	Intermediate gear - 92 teeth	D 201-251-501 & DA 201-251-301-501	1
A35d	5354211V	Intermediate gear - 116 teeth	202-252	1
A35d	5354212W	Intermediate gear - 142 teeth	302-502	1
A44d	7461030R	SIMRIT seal		1
A45d*	5354410L	Spacer collar	35 x 50 x 14	1
A46d	5354311D	Gear Slow Speed - 65 teeth	251	1
A46d	5354312E	Gear Slow Speed - 68 teeth	201	1
A46d	5354313F	Gear Slow Speed - 72 teeth	501-252	1
A46d	5354314G	Gear Slow Speed - 74 teeth	301-202-502	1
A46d	5354315H	Gear Slow Speed - 85 teeth	302	1
A47d	7424070S	Bearing	DA	1
A48d	7441636K	METAFRAM collar	D	1
A48d	7446501Y	METAFRAM collar	DA & RD	1
A241d	7281085Y	Cotter pin	8 x 7 x 50	1
A431d	7281114E	Cotter pin 10 x 8 x 60		2

4) Brake D & DA

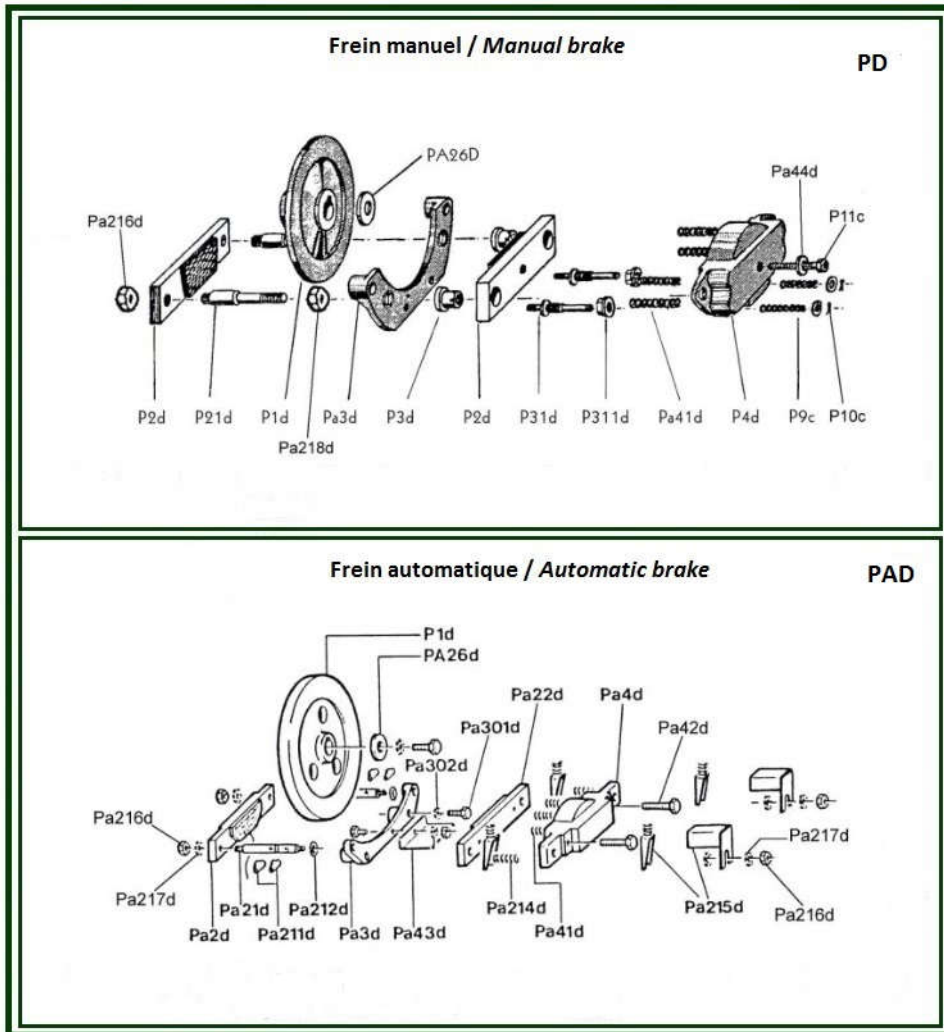

4.1) Manual brake

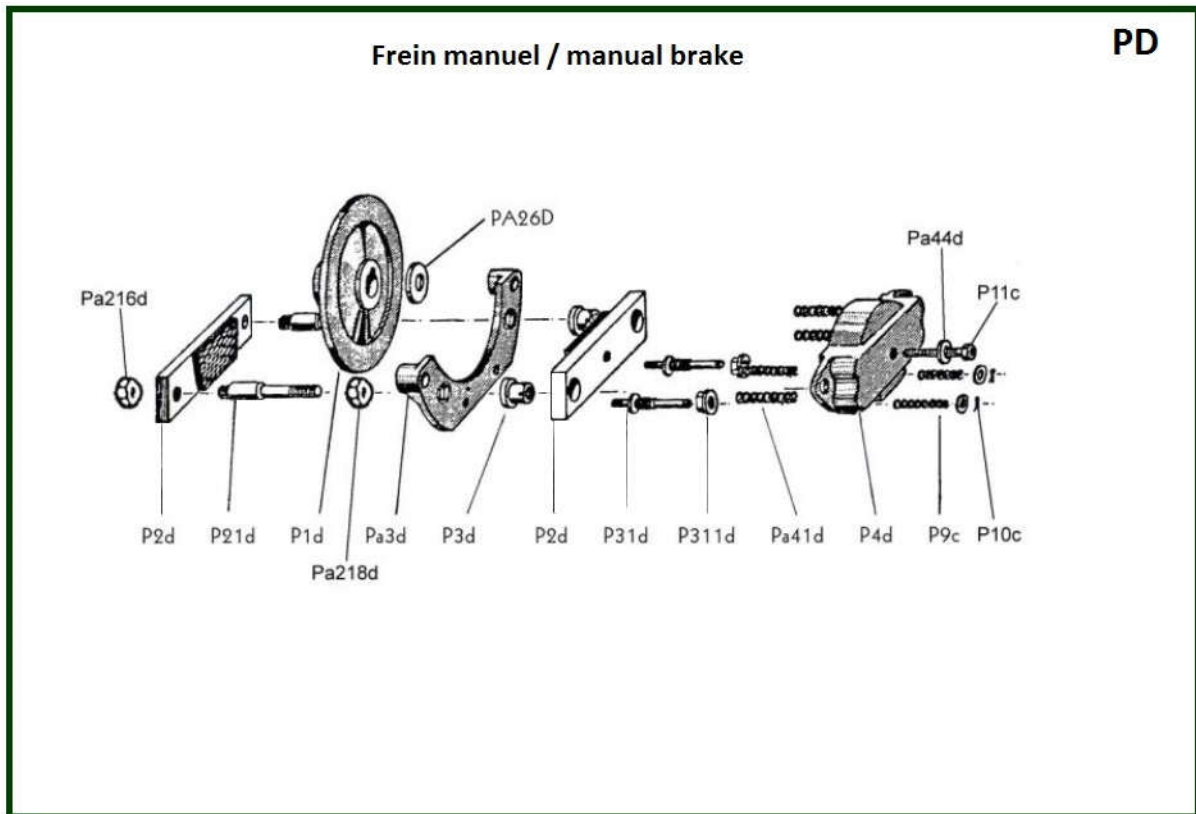

item	reference	description	observation	Quantity
P1d	5255201A	Brake disc	D & DA	1
P2d	EP1DK5071/72T	Set of brake jaws + bushes + studs		1
P3d	5275141Z	KNO stops		2
P4d	5255121P	Brake coil - 24V	Fils bleu et rouge / Blue and red wires	1
P4d	5255123R	Brake coil - 48V	Fils noir et blanc / Black and white wires	1
P9c	5235152H	Springs for studs		2
P10c	831660	Split spin 2 x 20		2
P11c	7211262D	HM screw 5 x 60		1
P21d	5255136E	Studs		2
P31d	5255142L	Studs for stop		2
P311d	5255144P	AKULON stops		2
Pa3d	5255124S	Brake support		1
Pa26D	7285050H	Disc washer	11 x 50 x 4	1
Pa41d	5255133B	Brake spring		4
Pa41d	5265133W	Brake spring	Uniquement / Only 7Kw	4
Pa44d	7231081W	Flat washer	Tambour D (5) - Tambour E (7)	1
Pa216d	7222100J	Flat nut-10mm		4
Pa218d	7221100X	HM nut - ø 10	D	2
PD	3255111Q	Complete manual brake without disc - 24V	D & DA	1
PD	3255118X	Complete manual brake without disc - 48V	D & DA	1
PD	3265119Y	Complete manual brake without disc - 48V	D & DA - 7.5kw	1

4.2) Automatic brake

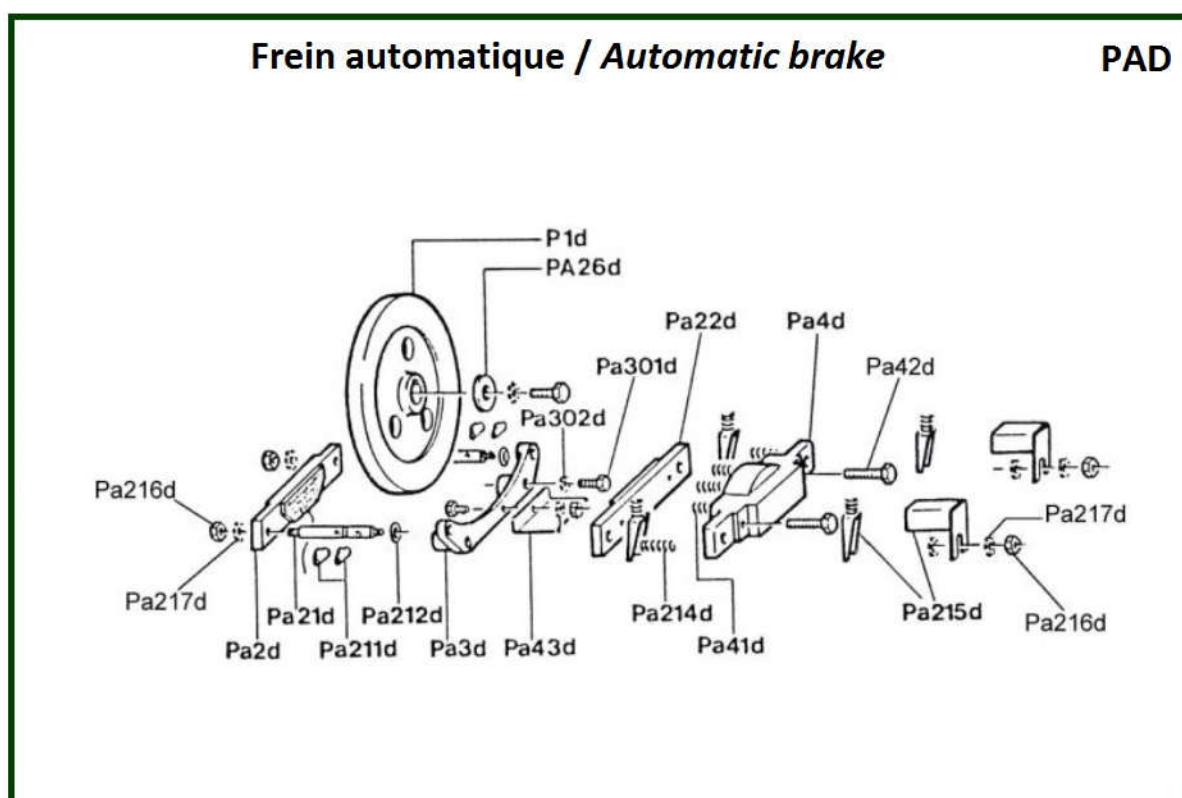

item	reference	description	observation	Quantity
P1d	5255201A	Brake disc	D & DA	1
Pa2d	5255134C	Brake shoes		1
Pa3d	5255124S	Brake support		1
Pa4d	5265121H	Brake coil - 24V	Fils bleu et rouge / Blue and red wires	1
Pa4d	5355122K	Brake coil - 48V	Fils noir et blanc / Black and white wires	1
Pa21d	5355131V	Axle		2
Pa22d	5255138G	Brake bar		1
Pa26d	7285050H	Disc washer	11 x 50 x 4	1
Pa41d	5255133B	Brake spring		4
Pa41d	5265133W	Brake spring	Uniquement / Only 7Kw	4
Pa43d	5355123L	Brake coil housing support		1
Pa211d	5255147S	Wedge follower		4
Pa212d	7791090B	Torque seal		2
Pa214d	5255150V	Gap control spring		2
Pa215d	PA215	Wedge guide (pressing spring+key)		2
Pa216d	7222100J	Flat nut-10mm		4
Pa217d	7232100D	Narrow Grower washer -10mm	DIN12	4
Pa301d	7211209W	HM screw 5 x 45		2
Pa302d	7231051P	Washer (5)		2
PAD	3255112R	Automatic brake complete without disc - 24V	D & DA	1
PAD	3255113S	Automatic brake complete without disc - 48V	DA	1
PAD	3255115U	Automatic brake complete Without disc - 48V	DA 7Kw	1

5) Brake for RD

Frein / Brake FCO-FCM-FCL

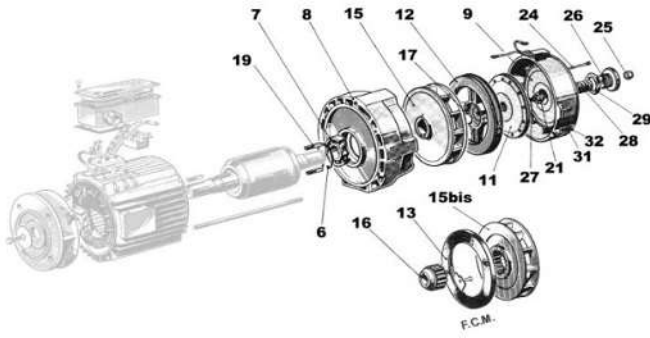

Frein / Brake GHUC

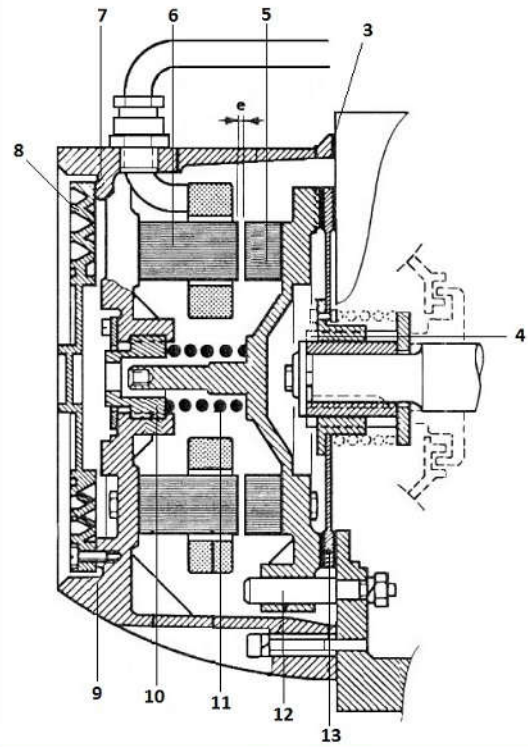

5.1) FCO - FCM - FCL brake for RD

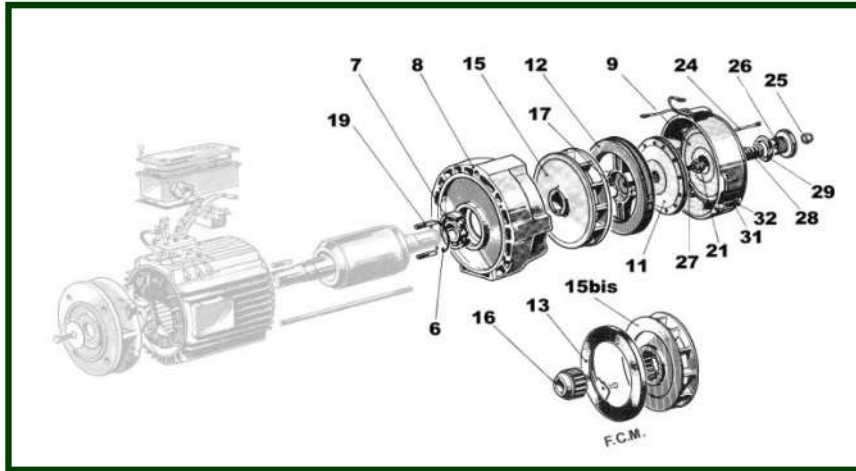

item	reference	description	observation	Quantity
11	342028323024	Frame - Brake FCL 132	Moteur 3141061510RD et 3141061511RD	1
11	342028223004	Frame LS100FCO - Brake FCO	Moteur 3141061500RD	1
11	314106150107	Frame LS112FCM - Brake FCM 112	Moteur 3141061501RD	1
13	314106150113	Brake lining - Brake FCM 112		1
15	314106150109	Brake disc - Brake FCM 112		1
15	342028223003	Brake disc - Brake FCO	15+17+19	1
15bis	343038223003	Brake disc with lining - Brake FCL 132		1
22	343038222007	Ventilator - Brake FCL 132		1
24	314106151049	100V cil set positionning screw Brake FCL 132		1
A	314106150112	Complete brake 20V - Brake FCM 112	9+11+12+15+17+19+21+24+25+26+27+28+29+31+32	1
A	342018203002	Complete brake 20V - Brake FCO	9+11+12+15+17+19+21+24+25+26+27+28+29+31+32	1
A	314106151050	Complete brake 100V - Brake FCL 132	9+11+12+15+17+19+21+24+25+26+27+28+29+31+32	1
B	343038223001	Brake set - Brake FCL 132	12+25+27	1
B	342028223002	Brake set - Brake FCM 112	12+25+27	1
C	342028323028	Brake torque adjustment set Brake FCL 132	25+26+27+28	1
C	342028223008	Brake torque adjustment set Brake FCM 112	25+26+28+29	1
D	342028223005	Coil set - Brake FCM 112	9+24+31+32	1
E	343038222008	Hub set - Brake FCL 132		1
E	314106150106	Hub set - Brake FCM 112	16+17+19	1

5.2) GHUC brake for RD

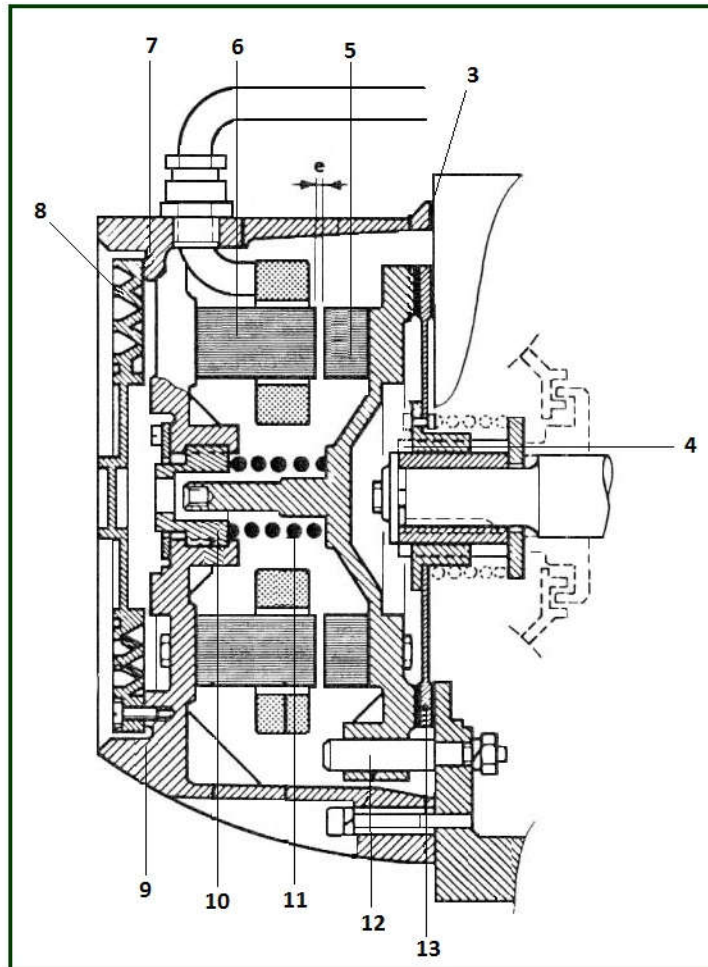

item	reference	description	observation	Quantity
1	314106151000	Complete brake GHUC 55 for 3 phases Motor type HFUCG - 112 220/380V	Moteur BBC - BBC MOTOR	1
1	314106151100	Complete brake GHUC 110 for 3 phases Motor type HFUCG - 132 220/380V	Moteur BBC - BBC MOTOR	1
4	314106151025	Splined bush for motor type HFUCG 112 with GHUC 55 brake	Moteur BBC - BBC MOTOR	1
4	314106151125	Splined bush for motor type HFUCG 132 with GHUC 110 brake	Moteur BBC - BBC MOTOR	1
6	314106151029	Brake coil GHUC 55 for motor type HFUCG 112	Moteur BBC - BBC MOTOR	1
6	314106151129	Brake coil GHUC 110 for motor type HFUCG 132	Moteur BBC - BBC MOTOR	1
13	314106151026	Brake disc GHUC 55 for motor type HFUCG 112	Moteur BBC - BBC MOTOR	1
13	314106151126	Brake disc GHUC 110 for motor type HFUCG 132	Moteur BBC - BBC MOTOR	1

6) Drum / Coupling

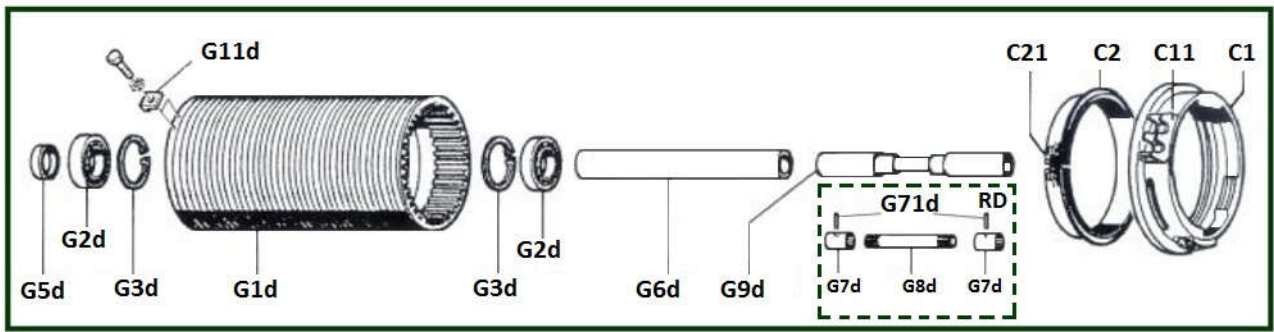

6.1) EUROBLOC D & DA

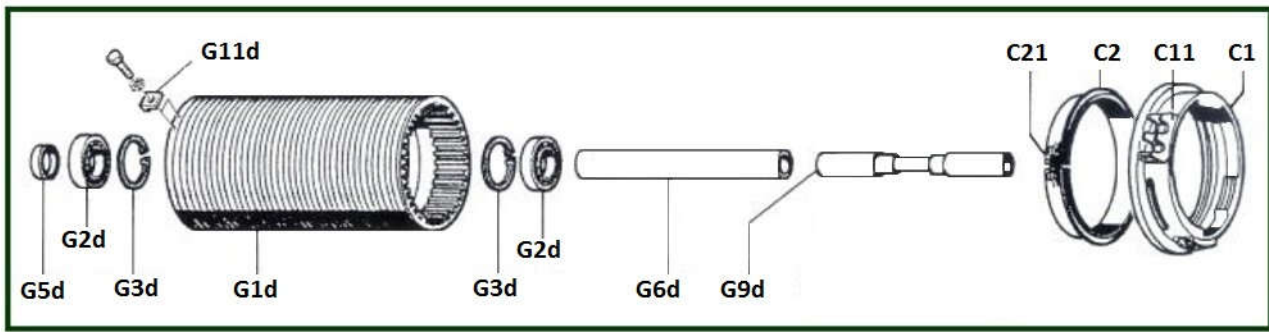

item	reference	description	observation	Quantity
-	5352101B	Drum and crown gear - 89 teeth		1
-	7281086Z	Key 8 x 7 x 60	Ø 400 - D, E, F	1
-	5252135T	Retaining plate		1
C1	3252322H	Complete left rope guide	4/2	1
C1	3252320F	Complete right rope guide	1/1 - 2/1 - 4/1 - 6/1	1
C2	E1PD202T	Nylon rope pressure spring		1
C11	5232342D	Traveller for rope guide		1
C21	5242332N	Pressure ring spring - 10,5		1
G1d	5252112T	Drum and crown gear	D-L - 1filet 12,5	1
G1d	5252122D	Drum and crown gear	D-L - 2 filets 12,5	1
G1d	5252111S	Drum and crown gear	D-N - 1filet 12,5	1
G1d	5252121C	Drum and crown gear	D-N - 2 filets 12,5	1
G1d	5252113U	Drum and crown gear	D-SL - 1filet 12,5	1
G1d	5252114V	Drum and crown gear	D-SSL - 1filet 12,5	1
G1d	5352111N	Drum and crown gear - Lg 402 mm	DA-RD-N - 1 filet 12,5 D	1
G1d	5352121Y	Drum and crown gear - Lg 402 mm	DA-RD-N - 2 filets 12,5	1
G1d	5352122Z	Drum and crown gear - Lg 617 mm	DA-RD-L - 2 filets 12,5	1
G1d	5352121P	Drum and crown gear - Lg 617 mm	DA-RD-L - 1 filet 12,5 D	1
G1d	5352113Q	Drum and crown gear - Lg 882 mm	DA-RD-SL - 1 filet 12,5 D	1
G1d	5352123A	Drum and crown gear - Lg 882 mm	DA-RD-SL - 2 filets 12,5	1
G1d	5352124B	Drum and crown gear - Lg 1017 mm	DA-RD-SSL - 2filets 12,5	1
G1d	5352114R	Drum and crown gear - Lg 1017 mm	RD SSL - 1 filet 12,5 D	1
G2d	5252136U	Spacer collar	D	1
G2d	5352135P	Spacer collar	DA-RD	1
G3d	7412121D	Bearing	D	2
G3d	7412170G	Bearing	DA-RD	2
G5d	7262085W	Exterior circlip	DA-RD	1
G5d	7261110L	Interior circlip 110	DA-RD	1
G6d	5252132Q	Central tube	D-L	1
G6d	5252131P	Central tube	D-N	1
G6d	5252133R	Central tube	D-SL	1
G6d	5252134S	Central tube	D-SSL	1
G6d	5352132K	Central tube DA	DA-RD-L	1
G6d	5352131J	Central tube DA	DA-RD-N	1
G6d	5352133L	Central tube DA	DA-RD-SL	1
G6d	5352134N	Central tube DA	DA-RD-SSL	1
G9d	3352420K	Driving axle - Lg 403mm- 18 splines	DA7KwN	1
G9d	3352410Z	Driving axle - Lg 403mm - 18 splines	DA-N 3 & 4,4Kw	1
G9d	3352421L	Driving axle - Lg 615mm - 18 splines	DA7Kw L	1
G9d	3352412B	Driving axle - Lg 882mm - 18 splines	DA-SL 3 & 4,4Kw	1
G9d	3352422N	Driving axle - Lg 882mm - 18 splines	DA7KwSL	1
G9d	3352413C	Driving axle - Lg 1015 mm - 18 splines	DA-SSL 3 & 4,4Kw	1
G9d	3252415J	Driving axle - Lg 403mm - 6 splines	D-N 3 & 4,4Kw	1
G9d	3352411A	Driving axle - Lg 615mm - 18 splines	DA-L 3 & 4,4Kw	1

G9d	<u>3252416K</u>	Driving axle - Lg 618mm- 6 splines	D-L 3 & 4,4Kw	1
G9d	<u>3252417L</u>	Driving axle - Lg 883mm - 6 splines	D-SL 3 & 4,4Kw	1
G9d	<u>3352423P</u>	Driving axle - Lg 1015mm - 18 splines	DA7KwSSL	1
G9d	<u>3252418N</u>	Driving axle - Lg 1018mm - 6 splines	D-SSL 3 & 4,4Kw	1
G11d	<u>8636251E</u>	Rope anchor on drum	DA-RD	2

6.2) RD

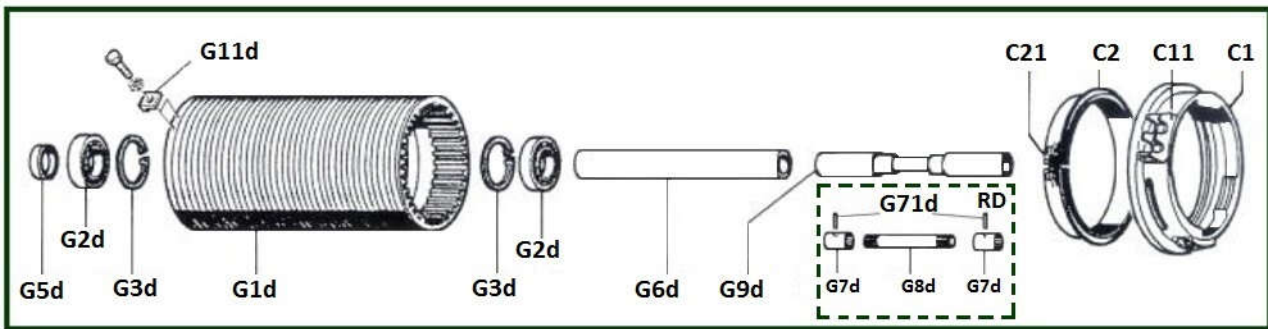

item	reference	description	observation	Quantity
C1	3252322H	Complete left rope guide	4/2	1
C1	3252320F	Complete right rope guide	1/1 - 2/1 - 4/1 - 6/1	1
C2	E1PD202T	Nylon rope pressure spring		1
C11	5232342D	Traveller for rope guide		1
C21	5242332N	Pressure ring spring - 10,5		1
G1d	5352111N	Drum and crown gear - Lg 402 mm	DA-RD-N - 1 filet 12,5 D	1
G1d	5352121Y	Drum and crown gear - Lg 402 mm	DA-RD-N - 2 filets 12,5	1
G1d	5352122Z	Drum and crown gear - Lg 617 mm	DA-RD-L - 2 filets 12,5	1
G1d	5352112P	Drum and crown gear - Lg 617 mm	DA-RD-L - 1 filet 12,5 D	1
G1d	5352113Q	Drum and crown gear - Lg 882 mm	DA-RD-SL - 1 filet 12,5 D	1
G1d	5352123A	Drum and crown gear - Lg 882 mm	DA-RD-SL - 2 filets 12,5	1
G1d	5352124B	Drum and crown gear - Lg 1017 mm	DA-RD-SSL - 2filets 12,5	1
G1d	5352114R	Drum and crown gear - Lg 1017 mm	RD SSL - 1 filet 12,5 D	1
G2d	5352135P	Spacer collar	DA-RD	1
G3d	7412170G	Bearing	DA-RD	2
G5d	7262085W	Exterior circlip	DA-RD	1
G6d	5352132K	Central tube DA	DA-RD-L	1
G6d	5352131J	Central tube DA	DA-RD-N	1
G6d	5352133L	Central tube DA	DA-RD-SL	1
G6d	5352134N	Central tube DA	DA-RD-SSL	1
G7d	5362435J	Bush		2
G8d	5352451G	Driving axle L		1
G8d	5352450F	Driving axle N		1
G8d	5352452H	Driving axle SL		1
G8d	5352453J	Driving axle SSL		1
G11d	8636251E	Rope anchor on drum	DA-RD	2
G71d	7273156E	Mecanindus pin		2

7) Overload limiter / Crosshead / Fixed point

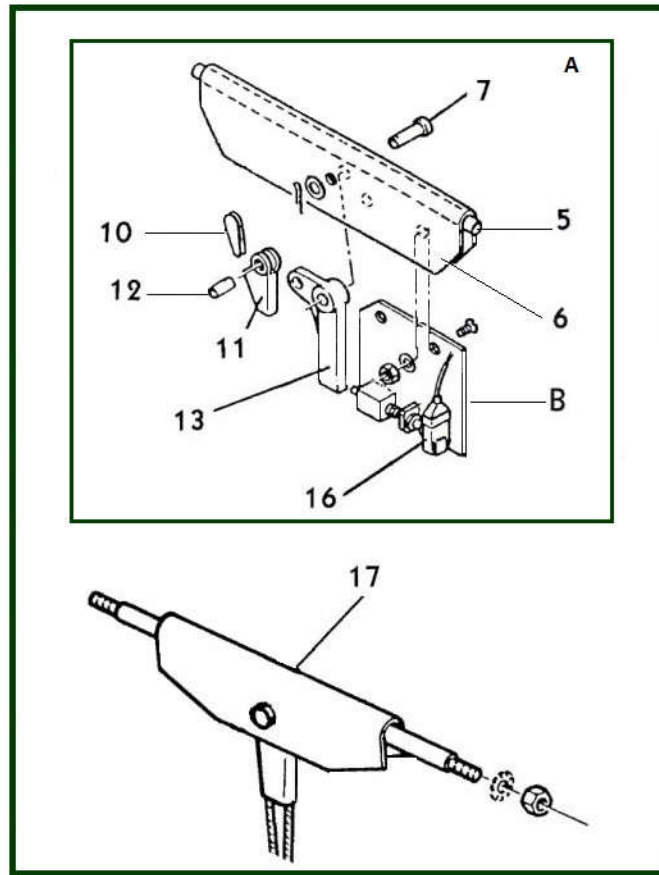

item	reference	description	observation	Quantity
5	5351302H	Rope guide spacer L	DA - Ø16	1
5	5351301G	Rope guide spacer N	DA - Ø16	1
5	5351303J	Rope guide spacer SL	DA - Ø16	1
5	5351304K	Rope guide spacer SSL	DA - Ø16	1
6	5251902Q	Support rope end limiter L	D & DA - Ø 11 mm	1
6	5351902K	Support rope end limiter L	DA - Ø 12 mm	1
6	5251901P	Support rope end limiter N	D & DA - Ø 11 mm	1
6	5351901J	Support rope end limiter N	DA - Ø 12 mm	1
6	5251903R	Support rope end limiter SL	D & DA - Ø 11 & 12mm	1
6	5251904S	Support rope end limiter SSL	D & DA - Ø 11 & 12mm	1
7	5251411F	Fixed point axle	D & DA - Ø 11 mm	1
7	5261411A	Shaft	DA - Ø 12 mm	1
10	8536225F	Rope attachment	D & DA - Ø 11 mm	1
10	8536228J	Rope wedge	Câble / Rope Ø 11 mm - DA	1
11	8536126Y	Rope attachment	Câble / Rope Ø 12 mm	1
11	8536125X	Rope wedge	Câble / Rope Ø 11 mmm - D & DA	1
12	5251441P	Rope attachment axis SL-SSL	D & DA - Ø 11 mm	1
12	5261451U	Rope attachment axis type N-L-SL-SSL	DA - Ø 12 mm	1
12	5251431C	Rope attachment axle N-L		1
13	5251432D	Right-angled lever N-L	D & DA - Ø 11 mm	1
13	5251442Q	Right-angled lever SL-SSL	D & DA - Ø 11 mm	1
13	5261452V	Right-angled lever type N-L-SL-SSL	DA - Ø 12 mm	1
16	7545111H	Load limiter electrical contact	Avant fin/Before end 1991	1
16	7545112J	Switch	Avant fin/Before end 1991	1
17	5251402W	Stirrup L	D & DA - Ø 11 mm	1
17	5351461F	Stirrup L	DA - 6/1	1
17	5351406W	Stirrup L	DA - Ø 12 mm	1

17	5251401V	Stirrup N	D & DA - Ø 11 mm	1
17	5351460E	Stirrup N	DA - 6/1	1
17	5351405V	Stirrup N	DA - Ø 12 mm	1
17	5251403X	Stirrup SL	D & DA - Ø 11 mm	1
17	5351462G	Stirrup SL	DA - 6/1	1
17	5351407X	Stirrup SL	DA - Ø 12 mm	1
17	5251404Y	Stirrup SSL	D & DA - Ø 11 mm	1
17	5351463H	Stirrup SSL	DA - 6/1	1
17	5351408Y	Stirrup SSL	DA - Ø 12 mm	1
A	2251911E	Limiter with support type L	Câble - Ø 11 mm	1
A	2351911A	Limiter with support type L	Câble - Ø 12 mm	1
A	2251910D	Limiter with support type N	Câble - Ø 11 mm	1
A	2351910Z	Limiter with support type N	Câble - Ø 12 mm	1
A	2251912F	Limiter with support type SL	Câble - Ø 11 mm	1
A	2351912B	Limiter with support type SL	Câble - Ø 12 mm	1
A	2251913G	Limiter with support type SSL	Câble - Ø 11 mm	1
A	2351913C	Limiter with support type SSL	Câble - Ø 12 mm	1
B	3251911L	Support plate complete without rolled plate suspension	D & DA	1

8) Return

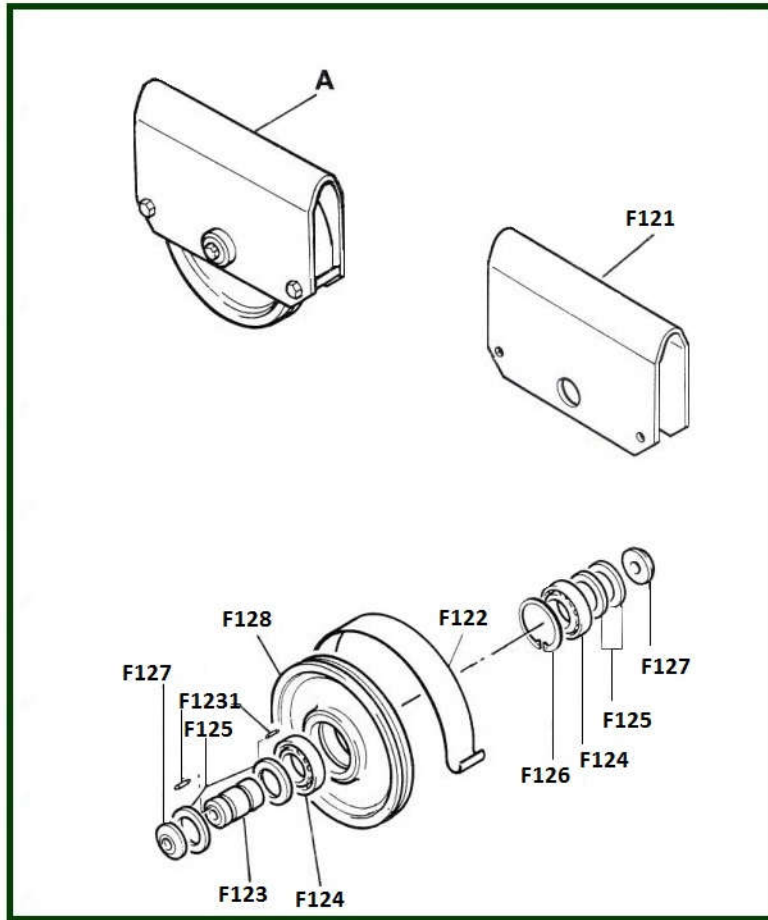

item	reference	description	observation	Quantity
A	4351560G	Complete return pulley assembly	DA & RD - 6/1	1
A	3251511B	Complete return pulley assembly L	D & DA - 4/1	1
A	3251510A	Complete return pulley assembly N	D & DA - 4/1	1
A	3251516G	Complete return pulley assembly SL	D & DA - 4/1	1
A	3251517H	Complete return pulley assembly SSL	D & DA - 4/1	1
F121	5251512R	Support type L	D & DA - 4/1	1
F121	5351561Q	Support type L	DA & RD - 6/1	1
F121	5251511Q	Support type N	D & DA - 4/1	1
F121	5351560P	Support type N	DA & RD - 6/1	1
F121	5251516V	Support type SL	D & DA - 4/1	1
F121	5351562R	Support type SL	DA & RD - 6/1	1
F121	5251517W	Support type SSL	D & DA - 4/1	1
F121	5351563S	Support type SSL	DA & RD - 6/1	1
F122	5251513S	Rope guide	D & DA & RD	1
F123	5253412F	Sheave pin	D & DA & RD	1
F124	7412111T	Bearing	D & DA & RD	2
F125	5251515U	Spacer collar	D & DA & RD	4
F126	300081	Interior circlip	D & DA & RD - 100 I	1
F127	5253622J	Axle washer	D & DA & RD	2
F128	5253620G	Pulley	D & DA & RD	1
F130	7211668V	HM screw 12 x 90	D & DA & RD	2
F131	7221120U	HM nut 12	D & DA & RD	2
F132	7232120A	Grower washer (12)	D & DA & RD	2
F1231	7273153B	Pin	D & DA & RD	2

9) Low headroom frame

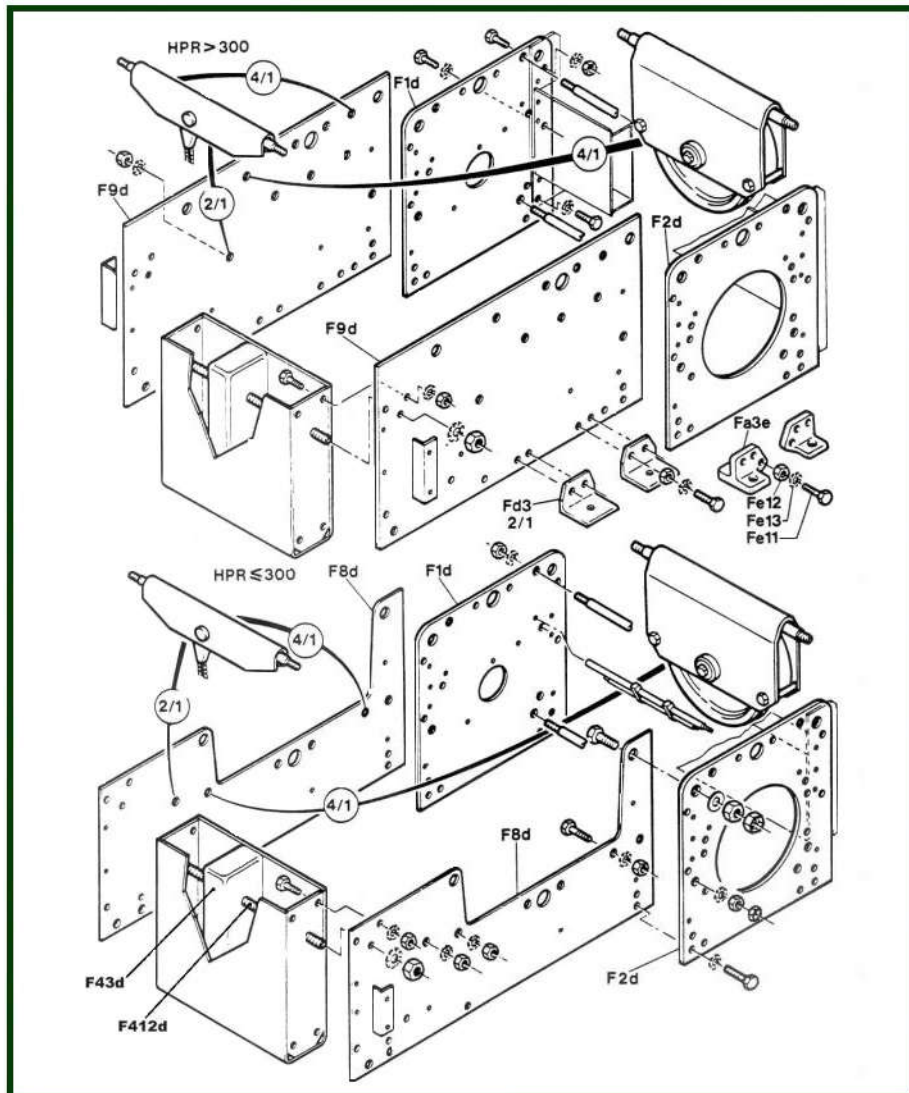

item	reference	description	observation	Quantity
F1d	5351103S	Casing flange - Motor side	DA	1
F2d	5351102R	Casing flange - Gearbox side	DA	1
F8d	5351104T	Additive side plateprofil = 320 palan 2/1 - 4/1	DA	1
F9d	5351105U	Additive side plateProfil > 300 palan 2/1 - 4/1	DA	1
F15d	5353101P	Cubicle support	DA	2
F43d	5355301P	Counterweight	DA	1
F412d	5353103R	Threaded rod L - SL - SSL	DA	1
F412d	5353102Q	Threaded rod N	DA	1
Fa3e	5452580T	Mounting cleat left	DA	2
Fa3e	5452581U	Mounting cleat right	DA	2
Fd3	5542580U	Foot mountings	DA	4
Fe11	7211912K	HM screw 20 x 60	DA	1
Fe12	831523	Nut H M20	C1	1
Fe13	7232200N	Washer		1

10) Normal headroom frame

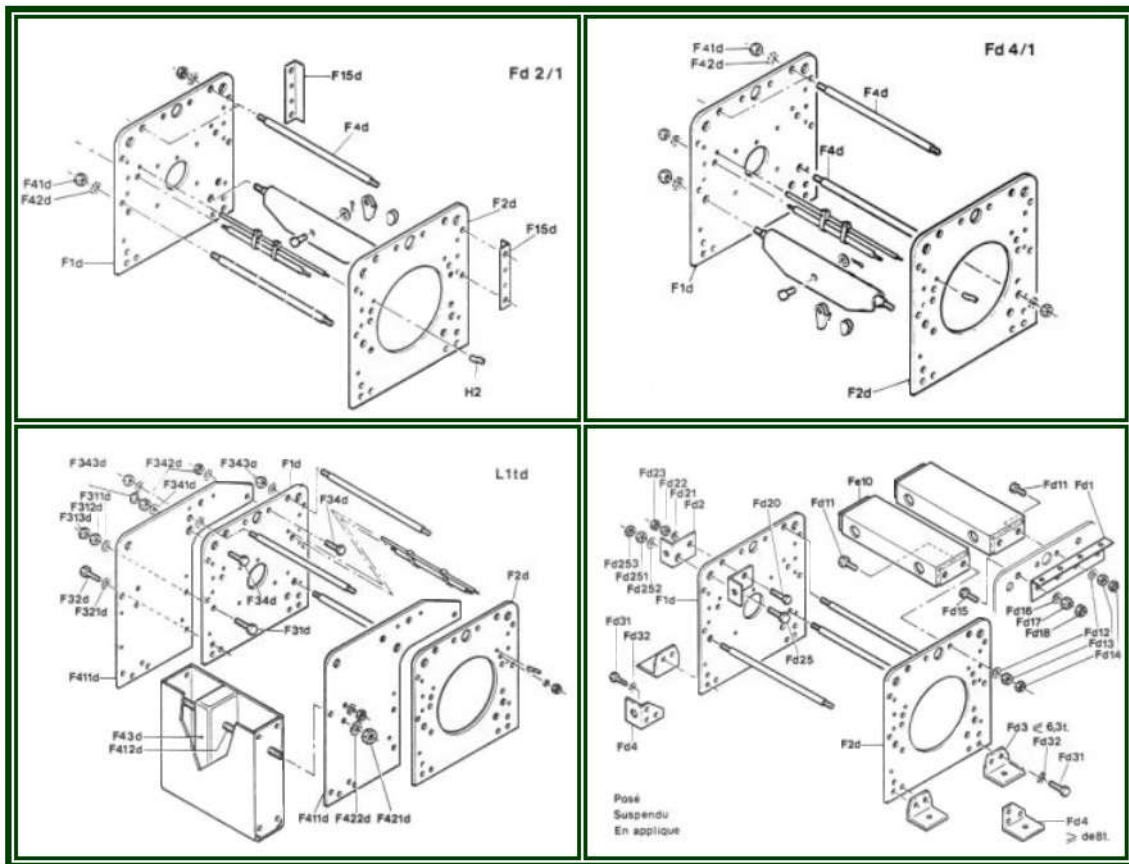

item	reference	description	observation	Quantity
F1d	5351103S	Casing flange - Motor side	DA	1
F2d	5351102R	Casing flange - Gearbox side	DA	1
F15d	5635005S	Cubicle support	DA	2
F43d	5355301P	Counterweight	DA	1
F411d	5351101Q	Additive side plate	DA	2
F412d	5353103R	Threaded rod L - SL - SSL	DA	1
F412d	5353102Q	Threaded rod N	DA	1
Fe10	5542511U	Cross head type L	DA	1
Fe10	5542510T	Cross head type N	DA	1
Fe10	5542512V	Cross head type SL	DA	1
Fe10	5542513W	Cross head type SSL	DA	1

11) Rope guide / Limit switch

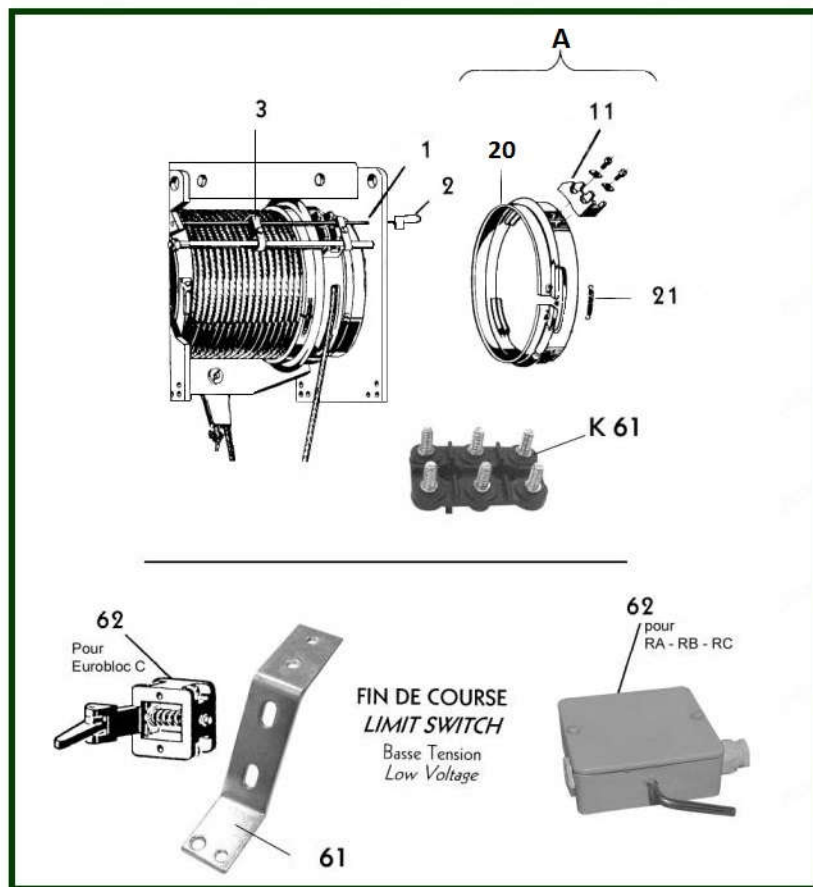

11.1) EUROBLOC D & DA

item	reference	description	observation	Quantity
1	5251332V	Limit switch operating rod L	D & DA - Lg 735 mm	1
1	5231332F	Limit switch operating rod L	Lg 525 mm	1
1	5251333W	Limit switch operating rod SL	D & DA - Lg 1000 mm	1
1	5251334X	Limit switch operating rod SSL	D & DA - Lg 1170 mm	1
2	5231343T	Threaded ferrule for limit rod		1
3	5231342S	Guide for tappets		2
3	7211254V	Screw		2
3	5231341R	Tappet		2
3	7232050Z	Washer		2
11	5232342D	Traveller for rope guide		1
20	E1PD202T	Nylon rope pressure spring		1
21	5242332N	Pressure ring spring - 10,5		1
61	5252316Q	Bracket	D-DA & RD	2
62	5632003T	Hoisting limit switch contact bracket	Basse tension / Low voltage	1
62	3632111X	Limit switch contact	Basse tension pour / Low voltage for C	1
-	7541412N	Limit switch contact - Top		1
A	3252322H	Complete left rope guide	4/2	1
A	3252320F	Complete right rope guide	1/1 - 2/1 - 4/1 - 6/1	1
T	5251302N	Rope guide spacer L	D - Ø16	1
T	5351302H	Rope guide spacer L	DA - Ø16	1
T	5351301G	Rope guide spacer N	DA - Ø16	1
T	5251301L	Rope guide spacer N	D - Ø16	1
T	5351303J	Rope guide spacer SL	DA - Ø16	1
T	5351304K	Rope guide spacer SSL	DA - Ø16	1
T	5251304Q	Rope guide spacer SSL	D - Ø16	1
T	5251303P	Rope guide spacer SL	D - Ø16	1

11.2) RD

item	reference	description	observation	Quantity
1	<u>3141061081RD</u>	Limit switch operating rod L	RD - Lg 735 mm	1
1	<u>3141061080RD</u>	Limit switch operating rod N	RD - Lg 525 mm	1
1	<u>3141061082RD</u>	Limit switch operating rod SL	RD - Lg 1000 mm	1
1	<u>3141061083RD</u>	Limit switch operating rod SSL	RD - Lg 1170 mm	1
3	<u>5231342S</u>	Guide for tappets		2
3	<u>7211254V</u>	Screw		2
3	<u>5231341R</u>	Tappet		2
3	<u>7232050Z</u>	Washer		2
11	<u>5232342D</u>	Traveller for rope guide		1
20	<u>E1PD202T</u>	Nylon rope pressure spring		1
21	<u>5242332N</u>	Pressure ring spring - 10,5		1
61	<u>5252316Q</u>	Bracket	D-DA & RD	2
62	<u>30140510515</u>	Limit switch contact	Basse tension / Low voltage	1
	<u>7541412N</u>	Limit switch contact - Top		1
A	<u>3252322H</u>	Complete left rope guide	4/2	1
A	<u>3252320F</u>	Complete right rope guide	1/1 - 2/1 - 4/1 - 6/1	1
T	<u>5351302H</u>	Rope guide spacer L	DA - Ø16	1
T	<u>5351301G</u>	Rope guide spacer N	DA - Ø16	1
T	<u>5351303J</u>	Rope guide spacer SL	DA - Ø16	1
T	<u>5351304K</u>	Rope guide spacer SSL	DA - Ø16	1

12) Hook block - 1 fall

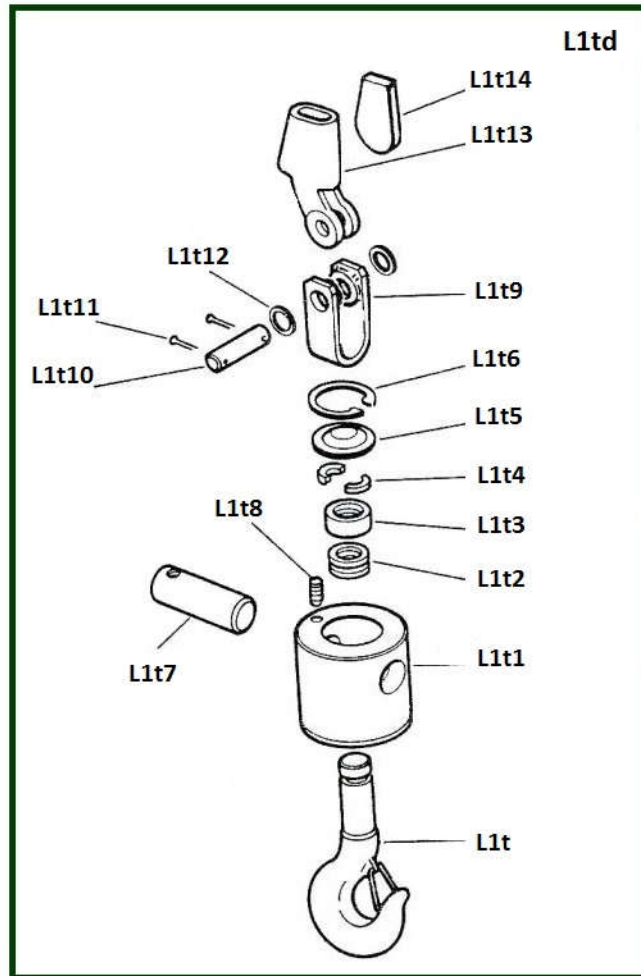

12.1) CABLE Ø 11 mm

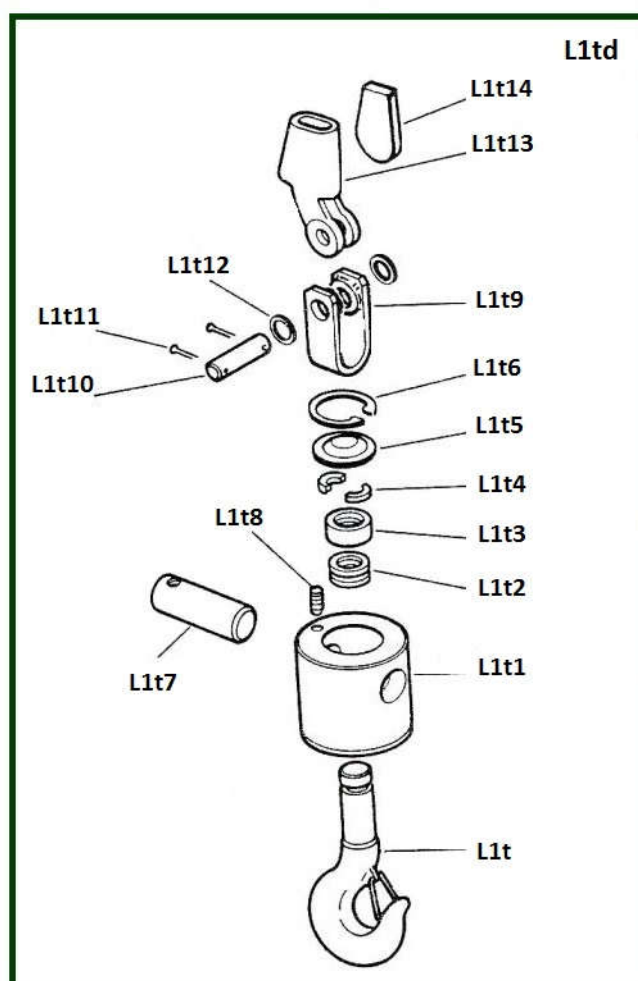

item	reference	description	observation	Quantity
-	SR32F	Safety catch (wire)	Câble / Rope Ø 11 & 12 mm	1
L1t1	5233301W	Washer	Câble / Rope Ø 11 & 12 mm	1
L1t2	7431062S	Thrust bearing		1
L1t3	5233612J	Cylindrical dish	Câble / Rope Ø 11 & 12 mm	1
L1t4	5233613K	Half segment ring	Câble / Rope Ø 11 & 12 mm	1
L1t5	5233615N	Cap	Câble / Rope Ø 11 & 12 mm	1
L1t6	7261080D	Internal circlip - Ø 80		1
L1t7	5233302X	Axle	Câble / Rope Ø 11 & 12 mm	1
L1t8	7217434N	Pointed screw	Câble / Rope Ø 11 & 12 mm	1
L1t9	5253311W	Stirrup	Câble / Rope Ø 11 mm	1
L1t10	5253312X	Rope attachment axle	Câble / Rope Ø 11 mm	1
L1t11	7271405B	Split pins	Câble / Rope Ø 11 mm	1
L1t12	7231162J	Plate washer	Câble / Rope Ø 11 mm	1
L1t13	8536125X	Rope wedge	Câble / Rope Ø 11 mm - D & DA	1
L1t14	8536228J	Rope wedge	Câble / Rope Ø 11 mm - DA	1
L1t	5233610G	Hook with safety catch		1
L1td	3253310G	Hook assembly - 1 fall	Câble / Rope Ø 11 & 12 mm	1

12.2) CABLE Ø 12 mm

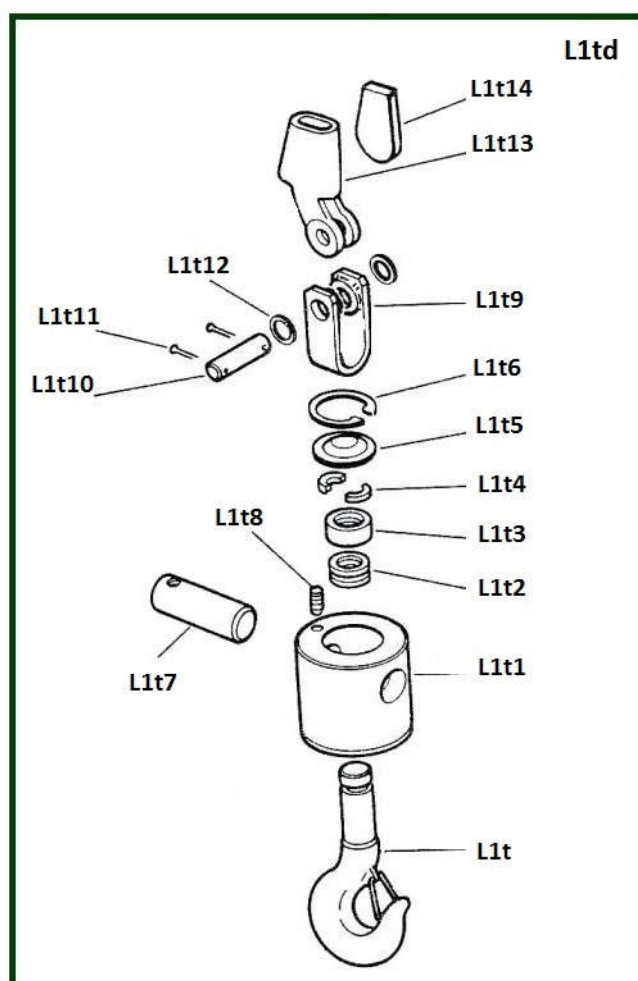

item	reference	description	observation	Quantity
	<u>SR32F</u>	Safety catch (wire)	Câble / Rope Ø 11 & 12 mm	1
L1t1	<u>5233301W</u>	Washer	Câble / Rope Ø 11 & 12 mm	1
L1t2	<u>7431062S</u>	Thrust bearing		1
L1t3	<u>5233612J</u>	Cylindrical dish	Câble / Rope Ø 11 & 12 mm	1
L1t4	<u>5233613K</u>	Half segment ring	Câble / Rope Ø 11 & 12 mm	1
L1t5	<u>5233615N</u>	Cap	Câble / Rope Ø 11 & 12 mm	1
L1t6	<u>7261080D</u>	Internal circlip - Ø 80		1
L1t7	<u>5233302X</u>	Axle	Câble / Rope Ø 11 & 12 mm	1
L1t8	<u>7217434N</u>	Pointed screw	Câble / Rope Ø 11 & 12 mm	1
L1t9	<u>5263311R</u>	Stirrup	Câble / Rope Ø 12 mm	1
L1t10	<u>5263312S</u>	Rope attachment axle	Câble / Rope Ø 12 mm	1
L1t11	<u>831656</u>	Split pin		2
L1t12	<u>400762</u>	Washer	C1 - Câble / Rope Ø 12 mm	2
L1t13	<u>8536126Y</u>	Rope attachment	Câble / Rope Ø 12 mm	1
L1t14	<u>8536128J</u>	Rope wedge	Câble / Rope Ø 11 & 12 mm	1
L1t	<u>5233610G</u>	Hook with safety catch		1
L1td	<u>2253311B</u>	Hook assembly - 1 fall	Câble / Rope Ø 12 mm	1

13) Hook block - 2 falls

3200 kg 1Am/5000 kg 1bm

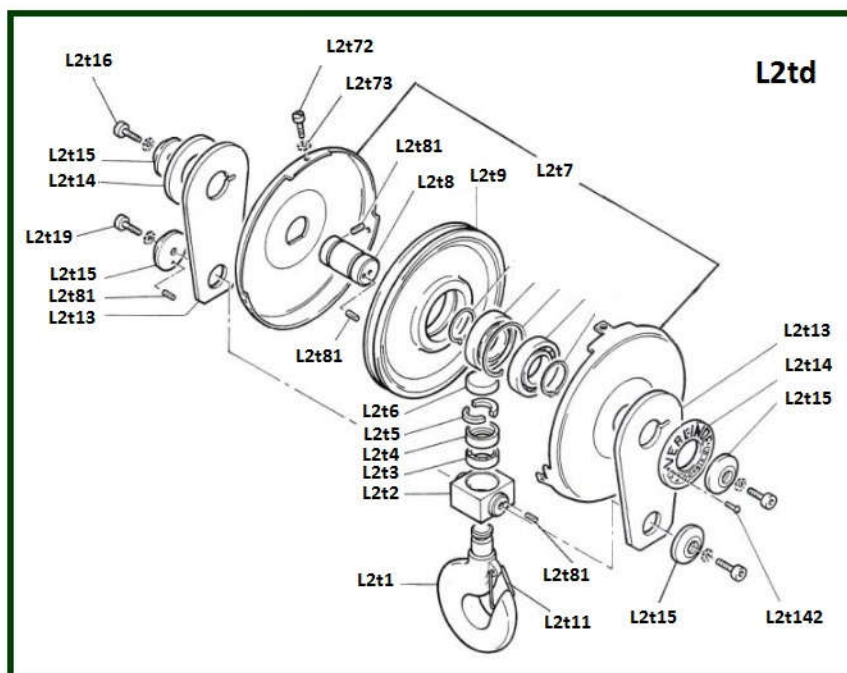

item	reference	description	observation	Quantity
L1t10	7262055P	Exterior circlip - Ø 55		2
L2t1	5243610B	Hook with safety catch		1
L2t2	5253414H	Hook crosshead		1
L2t3	7431081N	Thrust bearing		1
L2t4	5243612D	Seating ring		1
L2t5	5243613E	2 part collar		1
L2t6	5253416K	Cover		1
L2t7	3253510Q	Set of hook cover		1
L2t8	5253412F	Sheave pin	D & DA & RD	1
L2t9	5253620G	Pulley	D & DA & RD	1
L2t11	7412111T	Bearing	D & DA & RD	2
L2t11	SR40F	Safety catch steel		1
L2t11	SR40XP	Safety catch to be bolled on fook		1
L2t11	SR40X	Safety catch to be welden		1
L2t12	7261100A	Interior circlip - Ø 100		1
L2t13	5253415J	Strap		2
L2t14	KP3C2	Name plate blank		2
L2t14	KP3C1CD	Name plate VERLINDE		2
L2t14	KP12A2	SWL plate 2 groupe	Indiquer le groupe / Indicate the group	2
L2t14	KP12A16	SWL plate	1600 kg	2
L2t14	KP12A20	SWL plate	2000 kg	2
L2t14	KP12A25	SWL plate	2500 kg	2
L2t14	KP12A32	SWL plate	3200 kg	2
L2t15	5253622J	Axle washer	D & DA & RD	4
L2t16	7215455L	CHC screw 8 x 25	25 x 25	2
L2t17	7232080G	GROWER washer - Ø 8		4
L2t19	7215453J	Screw CHC 8x16	Vis pour rail / Screw for shaft	1
L2t72	7214352N	CBL screw 6 x 10	10 x 10	3
L2t73	7232060K	Washer M6	Standard	3
L2t81	7273153B	Pin	D & DA & RD	4
L2t142	7254409C	Blind		6
L2td	3253410R	Hook assembly - 2 falls	3200 kg	1
L2td	3243410W	Hook assembly - 2 falls	Câble/ Rope Ø 8,5 mm	1

14) Hook block - 4 falls

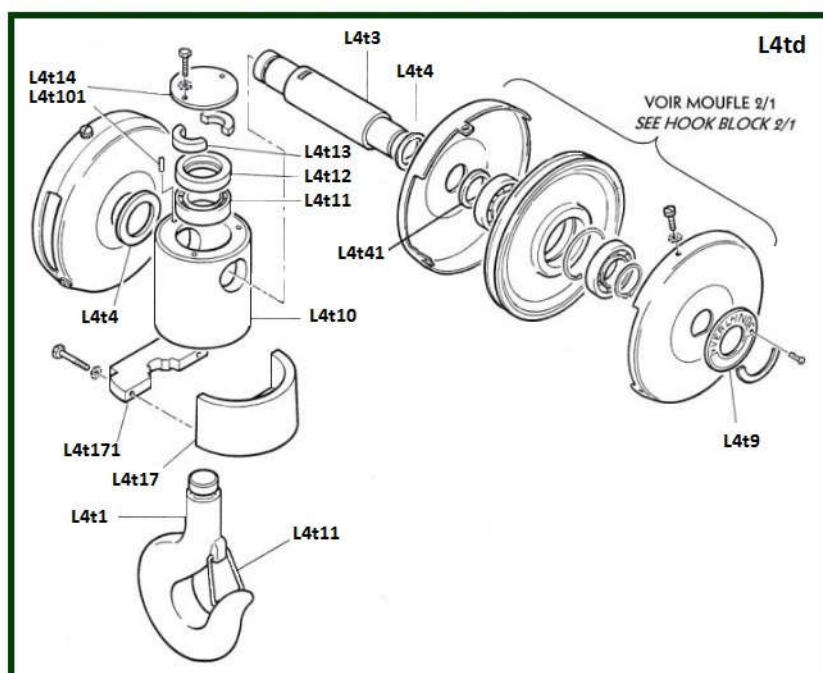

item	reference	description	observation	Quantity
1	5253610W	Hook with safety catch		1
3	5253611X	Axle of crosshead		1
4	5253616C	Spacer washer		2
9	7254409C	Blind		6
9	KP3C2	Name plate blank		2
9	KP3C1CD	Name plate VERLINDE		2
9	KP12A50	SWL plate	5000 Kg	2
9	KP12A63	SWL plate	6300 Kg	2
9	KP15A2	SWL plate	Groupe II	2
10	5253618E	Hook of crosshead		1
11	SR80F	Safety catch steel		1
11	SR80XP	Safety catch to be bolted on hook		1
11	7431112W	Thrust bearing		1
12	5253614A	Seating ring		1
13	5253613Z	2 part collar		1
14	5273419C	Thrust bearing cover		1
17	5253651R	Counterweight half	Option	1
41	5253617D	Spacer collar		2
101	7217434N	Pointed screw	Câble / Rope Ø 11 & 12 mm	1
171	5253650Q	Counterweight half		1
A	3253610H	Bottom block assembly - 4 falls	6300 Kg	1

15) Hook block - 6 falls

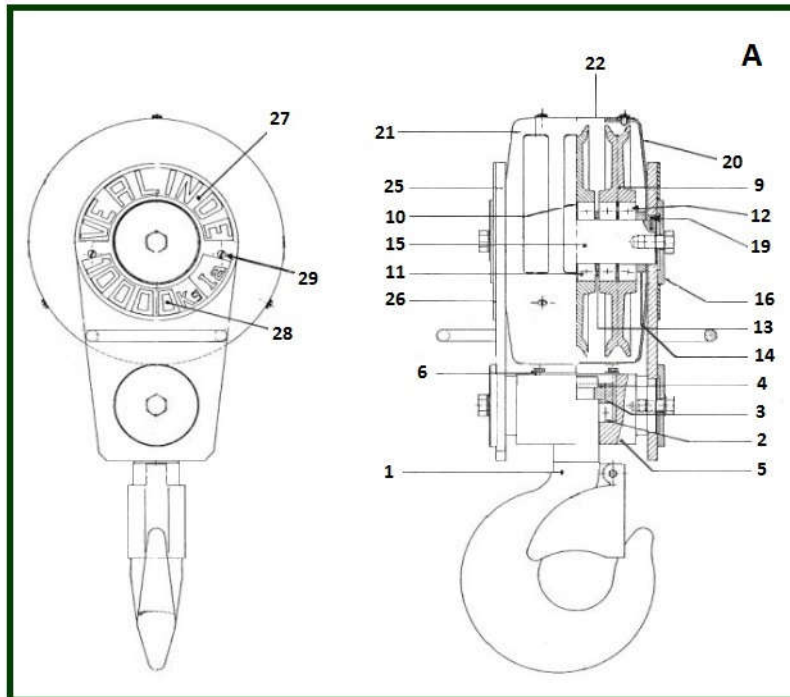

item	reference	description	observation	Quantity
1	5253610W	Hook with safety catch		1
2	7431112W	Thrust bearing		1
3	5253614A	Seating ring		1
4	5253613Z	2 part collar		1
5	5253812R	Crosshead		1
6	5273419C	Thrust bearing cover		1
9	5253620G	Pulley	D & DA & RD	3
10	7261100A	Interior circlip - Ø 100		3
11	7412111T	Bearing	D & DA & RD	6
12	5251525E	Spacer washer for bearings		3
13	5351567W	Spacer washer for pulleys		2
14	5351568X	Spacer washer		2
15	5253811Q	Sheave pin		1
16	5263616X	Washer		4
19	7273153B	Pin	D & DA & RD	1
20	5253411E	Half cover		1
21	5253410D	Half cover with lugs		1
22	5253813S	Hoop piece		1
25	5253801D	Bottom block support piece		2
26	KP4C	Company name plate		2
27	KP10AV	Company name plate VERLINDE		2
28	KP13A100	SWL plate	10 000 Kg	2
29	7214353P	Fixing screw		4
30	7211806V	Screw - HM 16 x 30		4
31	7232160U	Washer		4
A	3253810A	Hook block complet - 6 falls	DA 100	1

16) Monorail trolley type

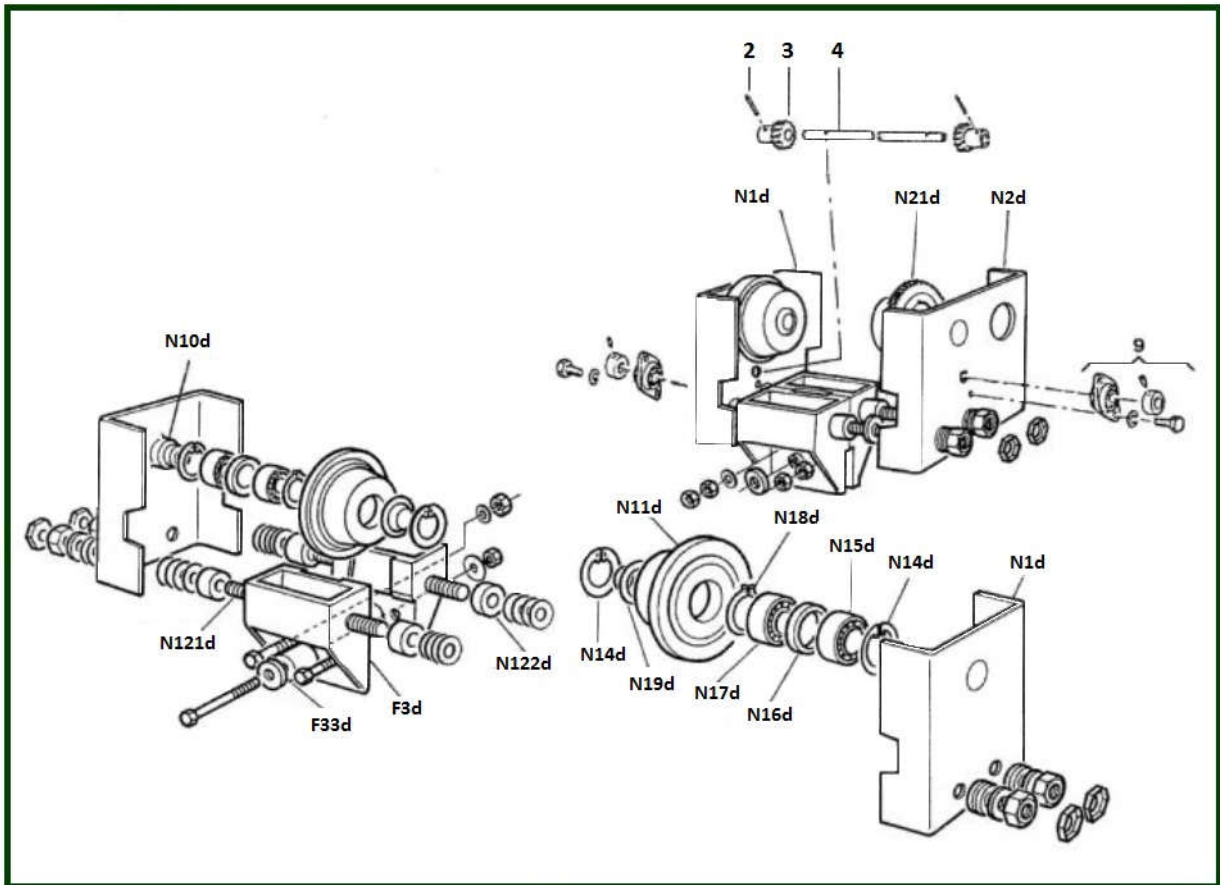

16.1) EUROBLOC D DA

item	reference	description	observation	Quantity
2	<u>7273356X</u>	MECANINDUS 6 x 30 pin		2
3	<u>5833520H</u>	Intermediate pinion	20 Dts / 20 th	2
4	<u>25015001</u>	Jackshaft	Fer 90 to 150 - Lg 340 mm	1
4	<u>25015002</u>	Jackshaft	Fer 151 to 200 - Lg 390 mm	1
4	<u>25015003</u>	Jackshaft	Fer 201 to 250 - Lg 440 mm	1
4	<u>25015004</u>	Jackshaft	Fer 252 to 300 - Lg 490 mm	1
9	<u>7447100Z</u>	Bearing PFT		2
	<u>7661106Q</u>	Earth brush	C1-C2-C3 - D & DA - 75 amp.	1
	<u>ECDK20T</u>	Geared wheel with fittings without axle	Ancien modèle	1
	<u>ECDK10T</u>	Idler runner with fittings without axle	Ancien modèle	1
	<u>7541312D</u>	Travel limit switch	C1-C2-C3	1
F3d	<u>14104-3304</u>	Crosshead		2
F3d	<u>5542252N</u>	Crosshead		2
F33d	<u>5542208Q</u>	Suspensions sleeves		2
N1d	<u>3541111J</u>	Ungeared side plate with fittings	Avant/Before 01/1986	3
N1d	<u>3541113L</u>	Ungeared side plate with fittings	Depuis/Since 01/1986	1
N1d	<u>3541114N</u>	Ungeared side plate with fittings - Driven runner	Depuis/Since 01/1986	1
N1d	<u>5541111X</u>	Ungeared side plate without fittings with axle	Avant/Before 01/1986	3
N1d	<u>5541113Z</u>	Ungeared side plate without fittings with axle	Depuis/Since 01/1986	2
N2d	<u>3541311B</u>	Geared side plate with fittings	Avant/Before 01/1986	1
N2d	<u>3541313D</u>	Geared side plate with fittings - Left end carriage	Depuis/Since 01/1986	1
N2d	<u>5541311Q</u>	Geared side plate without fittings with axle	Avant/Before 01/1986	1
N2d	<u>5541313S</u>	Geared side plate without fittings with axle	Depuis/Since 01/1986	1
N10d	<u>6541104W</u>	Axle		4
N11d	<u>4541111R</u>	Idler runner with fittings without axle		1
N11d	<u>5441151V</u>	Idler runner without fittings with axle	Ø 150 x 186	1
N14d	<u>7261080D</u>	Internal circlip - Ø 80		2
N15d	<u>7413070K</u>	Bearing		1
N16d	<u>5441152W</u>	Collar		1
N17d	<u>7412081K</u>	Bearing		1
N18d	<u>7262035S</u>	Circlip - Ø 35		1
N19d	<u>5233615N</u>	Cap	Câble / Rope Ø 11 & 12 mm	1
N21d	<u>4541311H</u>	Geared wheel with fittings without axle		1
N21d	<u>5441351N</u>	Geared wheel without fittings	Ø 150 x 186 - 60 dents / 60 teeth	1
N121d	<u>5442102D</u>	Spacer	Lg 370mm	4
N121d	<u>5452102Y</u>	Spacer	Lg 440mm	4
N121d	<u>5452106C</u>	Spacer	Lg 540mm	4
N122d	<u>5442116U</u>	Collar	ép. /th. 25mm	4
N122d	<u>5442117V</u>	Collar	ép. /th. 50mm	4

16.2) RD

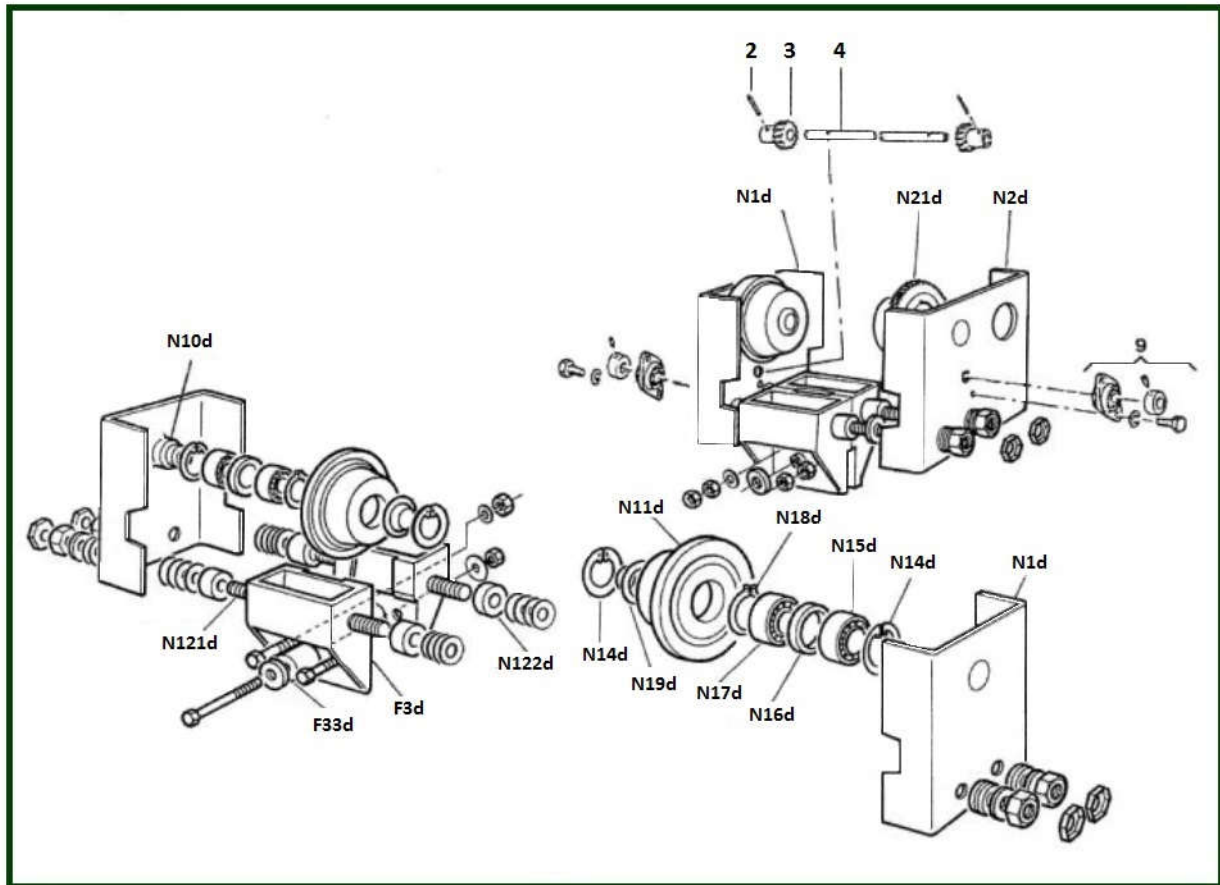

item	reference	description	observation	Quantity
2	7273356X	MECANINDUS 6 x 30 pin		2
3	33141043294	Intermediate pinion	13 Dts / 13 th	2
3	5833520H	Intermediate pinion	20 Dts / 20 th	2
4	25015001	Jackshaft	Fer 90 to 150 - Lg 340 mm	1
4	25015002	Jackshaft	Fer 151 to 200 - Lg 390 mm	1
4	25015003	Jackshaft	Fer 201 to 250 - Lg 440 mm	1
4	25015004	Jackshaft	Fer 252 to 300 - Lg 490 mm	1
9	7447100Z	Bearing PFT		2
-	7661106Q	Earth brush	C1-C2-C3 - D & DA - 75 amp.	1
-	7541312D	Travel limit switch	C1-C2-C3	1
=	ECDK20T	Geared wheel with fittings without axle	Ancien modèle	1
=	ECDK10T	Idler runner with fittings without axle	Ancien modèle	1
F3d	14104-3304	Crosshead		2
F3d	5542252N	Crosshead		2
F33d	5542208Q	Suspensions sleeves		2
N1d	3541111J	Ungeared side plate with fittings	Avant/Before 01/1986	3
N1d	3541113L	Ungeared side plate with fittings	Depuis/Since 01/1986	1
N1d	3541114N	Ungeared side plate with fittings - Driven runner	Depuis/Since 01/1986	1
N1d	5541111X	Ungeared side plate without fittings with axle	Avant/Before 01/1986	3
N1d	5541113Z	Ungeared side plate without fittings with axle	Depuis/Since 01/1986	2
N2d	3541311B	Geared side plate with fittings	Avant/Before 01/1986	1
N2d	3541313D	Geared side plate with fittings - Left end carriage	Depuis/Since 01/1986	1
N2d	5541311Q	Geared side plate without fittings with axle	Avant/Before 01/1986	1

N2d	5541313S	Geared side plate without fittings with axle	Depuis/Since 01/1986	1
N10d	6541104W	Axle		4
N11d	4541111R	Idler runner with fittings without axle		1
N11d	5441151V	Idler runner without fittings with axle	Ø 150 x 186	1
N14d	7261080D	Internal circlip - Ø 80		2
N15d	7413070K	Bearing		1
N16d	5441152W	Collar		1
N17d	7412081K	Bearing		1
N18d	7262035S	Circlip - Ø 35		1
N19d	5233615N	Cap	Câble / Rope Ø 11 & 12 mm	1
N21d	4541311H	Geared wheel with fittings without axle		1
N21d	5441351N	Geared wheel without fittings	Ø 150 x 186 - 60 dents / 60 teeth	1
N121d	5442102D	Spacer	Lg 370mm	4
N121d	5452102Y	Spacer	Lg 440mm	4
N121d	5452106C	Spacer	Lg 540mm	4
N122d	5442116U	Collar	ép. /th. 25mm	4
N122d	5442117V	Collar	ép. /th. 50mm	4

17) Trolley setting table

216	500	1	1	0	1	0
218	500	1	1	1/td>	1	0
220	500	1	1	0	0	1
222	500	1	1	0	1	1
224	500	1	1	0	1	1
226	500	1	1	1	1	1
228	500	1	1	0	0	2
230	500	1	1	1	0	2
232	500	1	1	0	1	2
234	500	1	1	1	1	2
236	500	1	1	0	0	3
238	500	1	1	1	0	3
240	500	1	1	0	1	3
242	500	1	1	1	1	3
244	500	1	1	0	0	4
246	500	1	1	1	0	4
248	500	1	1	0	1	4
250	500	1	1	1	1	4
252	500	1	1	0	0	5
254	500	1	1	1	0	5
256	500	1	1	0	1	5
258	500	1	1	1	1	5
260	500	0	2	1	0	0
262	500	0	2	0	1	0
264	500	0	2	1	1	0
266	500	0	2	0	0	1
268	500	0	2	1	0	1
270	500	0	2	0	1	1
271	500	0	2	1	1	1
274	500	0	2	0	0	2
276	500	0	2	1	0	2
278	500	0	2	0	1	2
280	500	0	2	1	1	2
282	500	0	2	0	0	3
284	500	0	2	1	0	3
288	500	0	2	0	1	3
288	500	0	2	1	1	3
290	500	0	2	0	0	4
292	500	0	2	1	0	4
294	500	0	2	0	1	4
296	500	0	2	1	1	4
298	500	0	2	0	0	5
298	500	0	2	1	0	5
216	500	1	1	0	1	0
218	500	1	1	1/td>	1	0
220	500	1	1	0	0	1
222	500	1	1	0	1	1
224	500	1	1	0	1	1
226	500	1	1	1	1	1
228	500	1	1	0	0	2
230	500	1	1	1	0	2
232	500	1	1	0	1	2
234	500	1	1	1	1	2
236	500	1	1	0	0	3
238	500	1	1	1	0	3
240	500	1	1	0	1	3
242	500	1	1	1	1	3
244	500	1	1	0	0	4
246	500	1	1	1	0	4
248	500	1	1	0	1	4
250	500	1	1	1	1	4
252	500	1	1	0	0	5
254	500	1	1	1	0	5
256	500	1	1	0	1	5
258	500	1	1	1	1	5
260	500	0	2	1	0	0
262	500	0	2	0	1	0
264	500	0	2	1	1	0
266	500	0	2	0	0	1
268	500	0	2	1	0	1
270	500	0	2	0	1	1
271	500	0	2	1	1	1
274	500	0	2	0	0	2
276	500	0	2	1	0	2
278	500	0	2	0	1	2
280	500	0	2	1	1	2
282	500	0	2	0	0	3
284	500	0	2	1	0	3
286	500	0	2	0	1	3
288	500	0	2	1	1	3
290	500	0	2	0	0	4
292	500	0	2	1	0	4
294	500	0	2	0	1	4
296	500	0	2	1	1	4
298	500	0	2	0	0	5
300	500	0	2	1	0	5

18) Swivelling trolley -Type II 78

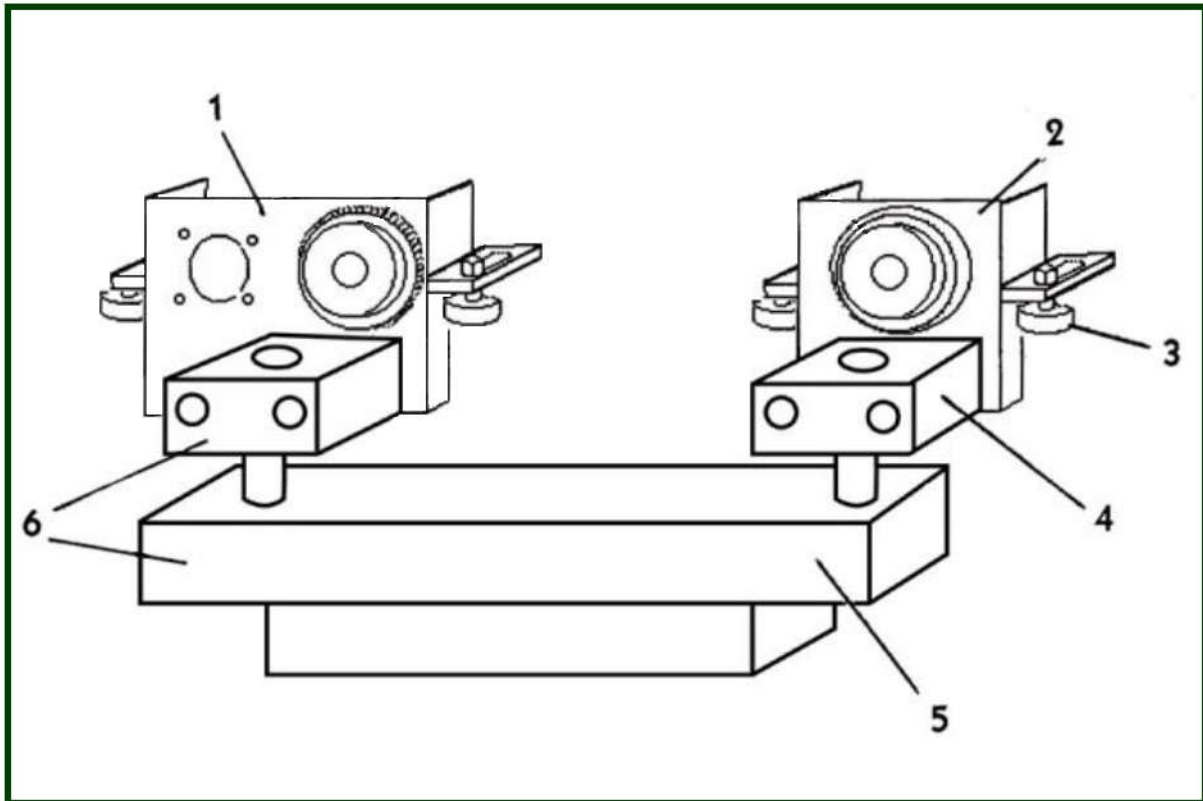

item	reference	description	observation	Quantity
1	3511311T	Geared side plate with fittings		2
1	5511311F	Geared side plate without axle and support		2
2	3511111A	Ungeared side plate with fittings		2
2	5511111P	Ungeared side plate without fittings with axle and support		2
3	5501203U	Axle		1
3	7412045W	Bearing		1
3	5431153C	Cover	I/77	1
3	830860	Exterior circlip - Ø 20	C2	1
3	4501211W	Guiding wheel set		4
3	300077	Interior circlip	D et DA - I/77 - Ø 47	2
3	5501207Y	Wheel		1
4	5512106V	Crosshead only		2
5	5512108X	Crosshead type L		1
5	5512107W	Crosshead type N		1
5	5512109Y	Crosshead type SL		1
5	5512110Z	Crosshead type SSL		1
5	6512112H	Pivot only		2
6	4512101H	Complete crosshead N	Avec traverse rotation /With crossbar rotation	1
	7431073D	Thrust bearing	Avant / Before 94	2
	7431074E	Thrust bearing	Depuis / Since 94	2

19) Double girder trolley

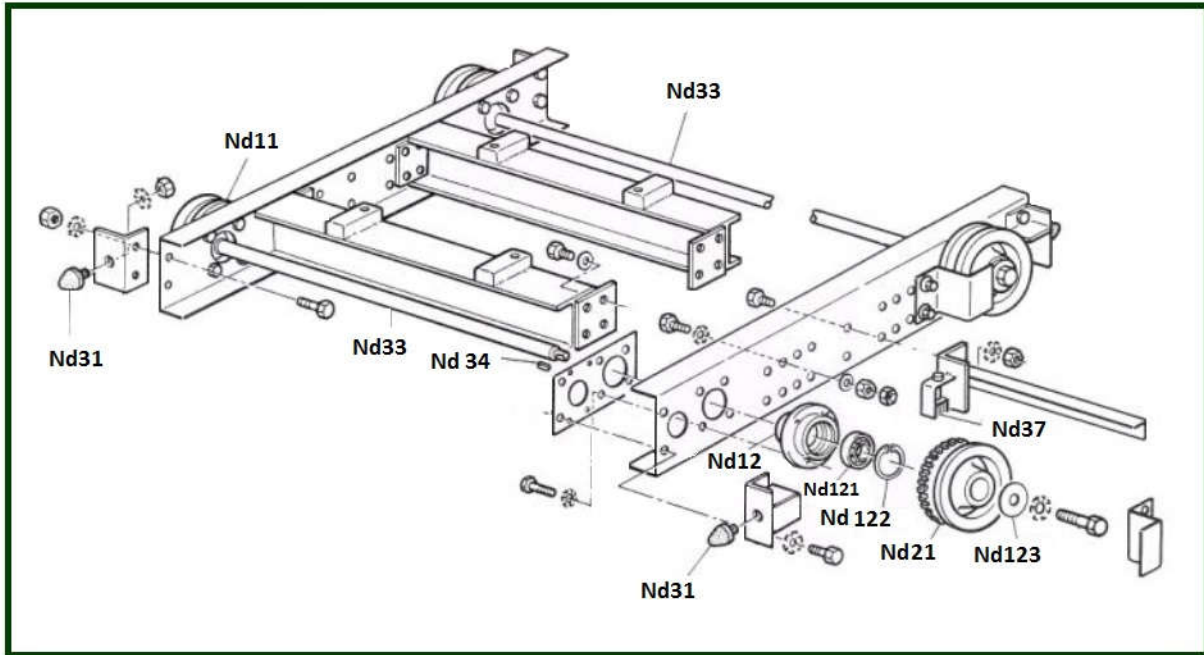

item	reference	description	observation	Quantity
Nd11	5471151D	Idler runner - Ø160		3
Nd11	5481151Y	Idler runner - Ø200		3
Nd11	5571151Z	Idler runner - Ø200	Depuis / Since 06 / 83	3
Nd12	5571010W	Bearing housing	Depuis / Since 06 / 83	4
Nd21	5471352X	Driven runner - Ø160		1
Nd21	5481352S	Driven runner - Ø200 - 76 teeth	63 mm	1
Nd21	5571351S	Driven runner - Ø200 - 76 teeth	Depuis / Since 06 / 83 71 mm	1
Nd31	7910802Y	Rubber buffer	Ø 80	4
Nd33	5572214E	Shaft - 1,4m		2
Nd33	5472221S	Shaft - 1,4m	Galet / Wheel Ø160	2
Nd33	5482221L	Shaft - 1,4m	Pour galet / For wheel Ø200	2
Nd33	5482211A	Shaft - 1m	Avant / Before 06 / 83 - Galet / Wheel - Ø200	2
Nd33	5472211F	Shaft - 1m	Galet / Wheel Ø160	2
Nd33	5572210A	Shaft groove - 1m		2
Nd34	7281142K	Key		4
Nd37	7661106Q	Earth brush	C1-C2-C3 - D & DA - 75 amp.	1
Nd121	7425100L	Bearing		4
Nd121	7412101G	Bearing	Après / After 06 / 83	4
Nd121	7417085Z	Bearing	Galet / Wheel Ø160	4
Nd121	7261090Q	Interior circlip		4
Nd121	5571012Y	Washer		4

20) Bissel trolley (HPR72) for D type only

Nous consulter - Matériel sur commande / Consult us - Materiel to be ordered

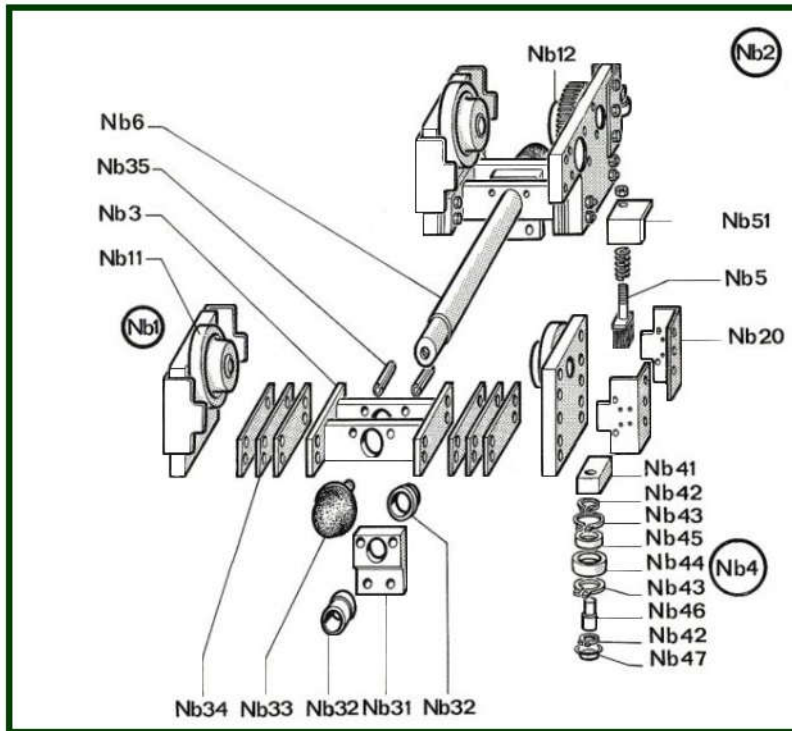

21) NA trolley for D type only

Nous consulter - Matériel sur commande / Consult us - Materiel to be ordered

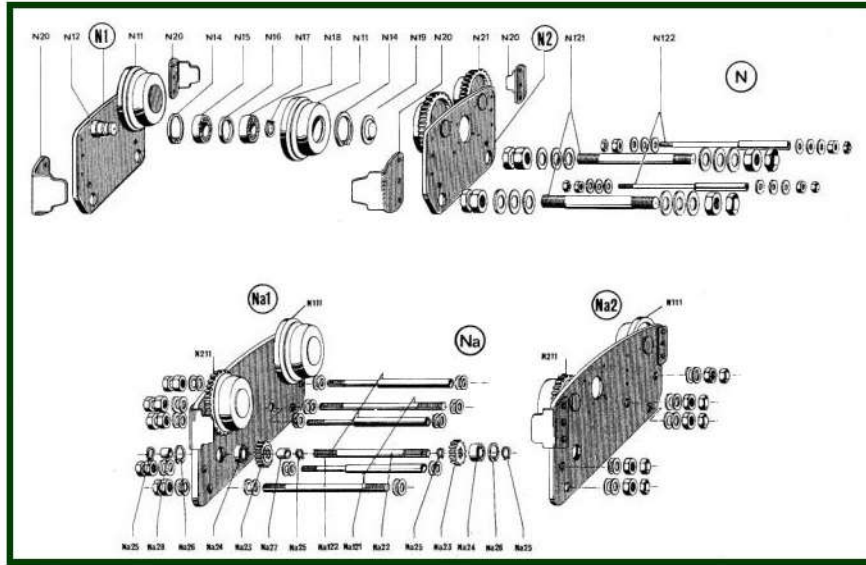

22) Gear and motorgear

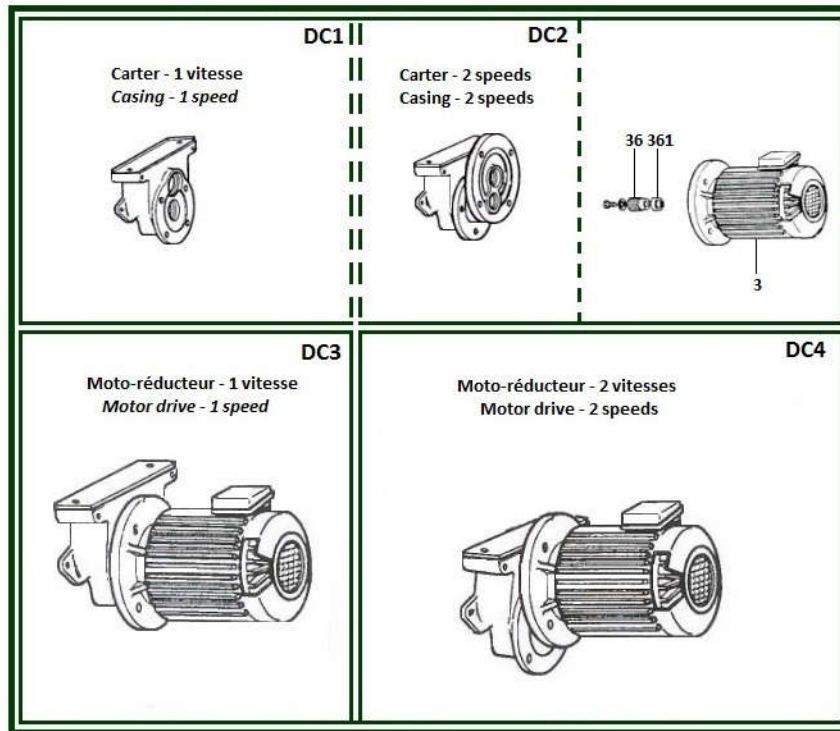

22.1) DC1

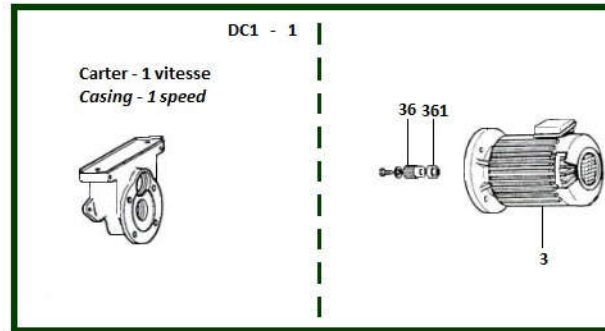

item	reference	description	observation	Quantity
1	3544011L	Gear 10 or 20/5m/mn - 16 teeth	DC1 - HPR72 (chariot Bissel)	1
1	3444013T	Gear 20 or 30m/mn - 11 teeth	DC1	1
1	3444010Q	Gear 20 or 30m/mn - 16 teeth	DC1	1
1	3544010K	Gear 20 or 30 m/mn - 16 teeth	DC1 - HPR72 (chariot Bissel)	1
3	7350272B	Brake motor LS71FAST 0,37Kw 1500t/mn 220/380V	Bride 140 BA 14x30	1
3	7350151V	Brake motor LS71FCR 0,25 Kw 1000t/mn 220/380V	Bride 140 BA 14x30	1
3	7350271A	Brake motor LS71FCR 0,37Kw 1500t/mn 220/380V	Bride 200 BA 14x30	1
3	7352401R	Brake motor LS71FCR 0,55/0.12 Kw 3000/750t/mn 220/380V	Bride 200BA 14x30	1
3	7352261P	Brake motor LS80FAST 0,75Kw 1500t/mn 220/380V	Bride 140BA 14x30	1
3	7352267V	Brake motor LS80FAST 0,75Kw 1500t/mn 220/380V	Bride 200BA 14x30	1
3	7352760F	Brake motor LS80FAST 0,75Kw 1500t/mn 240/415V	Plus fourni / No more supplied	1
3	7352011S	Brake motor LS80FCR 0,18Kw 750t/mn 220/380V	Bride 200 BA 14x30	1
3	7352171R	Brake motor LS80FCR 0,55Kw 1000t/mn 220/380V	Bride 140BA 14x30 - Frein/brake FCR 180VDC	1
3	7352177X	Brake motor LS80FCR 0,55Kw 1000t/mn 220/380V	Bride 200BA 14x30	1
3	7353407J	Brake motor LS90FAST 0,48/0,12Kw 3000/750t/mn 220/380V	Bride 200BA 14x30	1
36	5438101E	Motor pinion - 23 teeth	Alésage / Bore 14 - A,D	1
36	5438103G	Motor pinion - 32 teeth	Alésage / Bore 14 - B,C,E	1
361	5438111R	Collar pinion motor	A,D	1
361	5438112S	Pinion collar	B,C,E	1

22.2) DC2

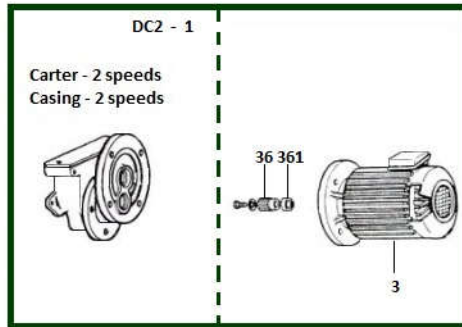

item	reference	description	observation	Quantity
1	3444014U	Gear 5 or 10m/mn - 11 teeth		1
1	3444011R	Gear 10 or 20/5 m/mn - 16 teeth		1
1	3444015V	Gear 30/7,5m/mn - 11 teeth		1
3	7350272B	Brake motor LS71FAST 0,37Kw 1500t/mn 220/380V	Bride 140 BA 14x30	1
3	7350151V	Brake motor LS71FCR 0,25 Kw 1000t/mn 220/380V	Bride 140 BA 14x30	1
3	7350271A	Brake motor LS71FCR 0,37Kw 1500t/mn 220/380V	Bride 200 BA 14x30	1
3	7352401R	Brake motor LS71FCR 0,55/0.12 Kw 3000/750t/mn 220/380V	Bride 200BA 14x30	1
3	7352261P	Brake motor LS80FAST 0,75Kw 1500t/mn 220/380V	Bride 140BA 14x30	1
3	7352267V	Brake motor LS80FAST 0,75Kw 1500t/mn 220/380V	Bride 200BA 14x30	1
3	7352760F	Brake motor LS80FAST 0,75Kw 1500t/mn 240/415V	Plus fourni / No more supplied	1
3	7352011S	Brake motor LS80FCR 0,18Kw 750t/mn 220/380V	Bride 200 BA 14x30	1
3	7352171R	Brake motor LS80FCR 0,55Kw 1000t/mn 220/380V	Bride 140BA 14x30 - Frein/brake FCR 180VDC	1
3	7352177X	Brake motor LS80FCR 0,55Kw 1000t/mn 220/380V	Bride 200BA 14x30	1
3	7353407J	Brake motor LS90FAST 0,48/0,12Kw 3000/750t/mn 220/380V	Bride 200BA 14x30	1
36	5438101E	Motor pinion - 23 teeth	Alésage / Bore 14 - A,D	1
36	5438103G	Motor pinion - 32 teeth	Alésage / Bore 14 - B,C,E	1
361	5438111R	Collar pinion motor	A,D	1
361	5438112S	Pinion collar	B,C,E	1

22.3) DC3

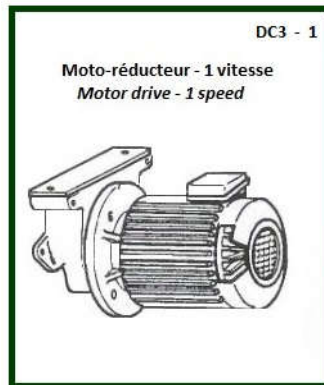

item	reference	description	observation	Quantity
1	<u>2548143W</u>	Motor drive - 10 m/mn	220/380V 50HZ-PA - 11 dents/theeth Bride / Clamp 200	1
1	<u>2548163T</u>	Motor drive - 20 m/mn	220/380V 50HZ-PA - 11 dents/theeth Bride / Clamp 140	1
1	<u>2548173D</u>	Motor drive - 30 m/mn	220/380V 50HZ-PA - 11 dents/theeth Bride / Clamp 140	1
1	<u>3447561Z</u>	Motorgear 10m/mn - 16 teeth	220-380V	1
1	<u>3447441U</u>	Motorgear 20m/mn - 16 teeth	220-380V	1
1	<u>2447461J</u>	Motorgear 30m/mn - 16 teeth	220-380V	1
1a	<u>3547861W</u>	Motorgear 10m/mn - 16 teeth	HPR72 (chariot Bissel)	1
1a	<u>3547741R</u>	Motorgear 20m/mn - 16 teeth	HPR72 (chariot Bissel) - Ø100	1

22.4) DC4

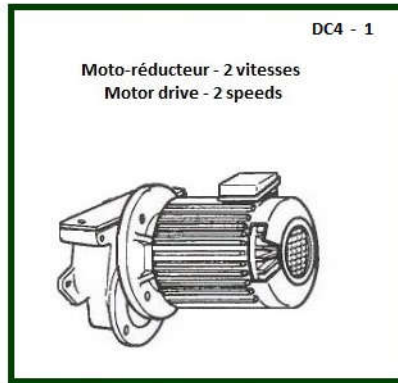

item	reference	description	observation	Quantity
1	2548263B	Motor drive 2- 0&5 m/mn	220/380V 50HZ-PA - 11 dents/theeth Bride / Clamp 200	1
1	3447571K	Motorgear 20/5m/mn - 16 teeth	220-380V D50-D63 birail	1
1	3547881T	Motorgear 20/5m/mn - 16 teeth	(HPR72(chariot Bissel)/ HPN) D25-D63	1

23) Electric travel and chain travel

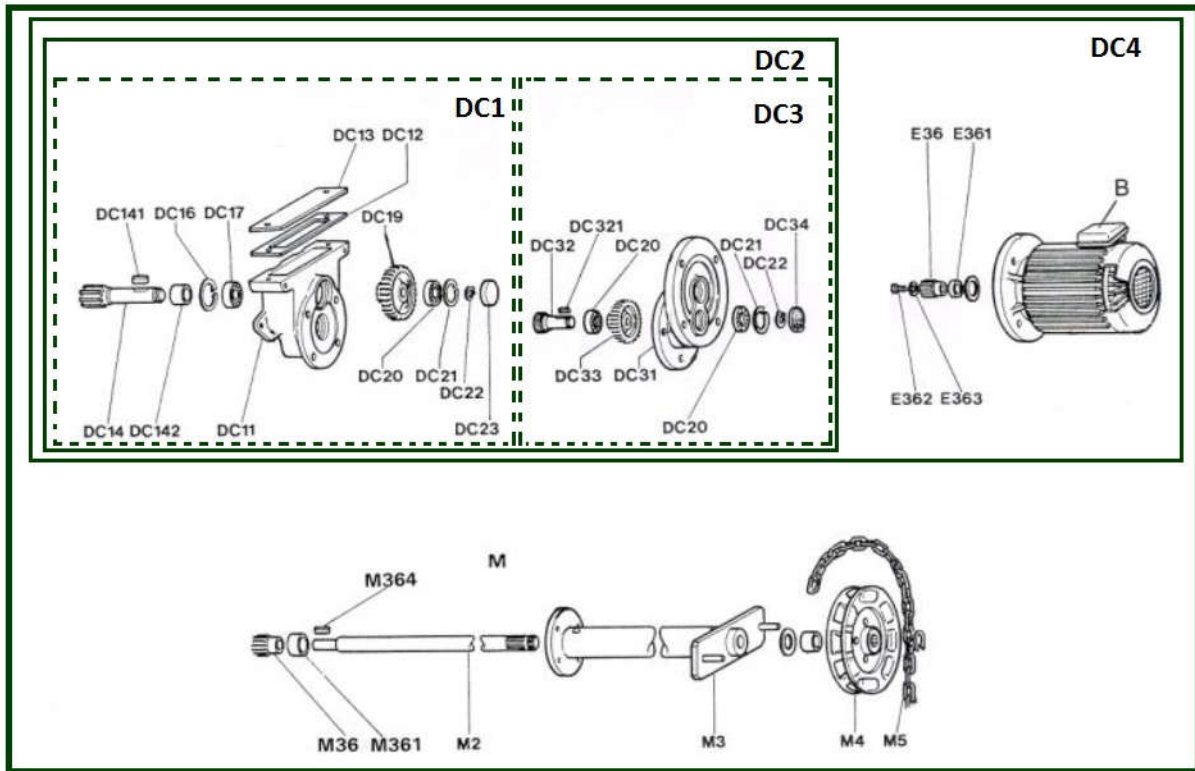

item	reference	description	observation	Quantity
	5434107P	Breather		1
	5434106N	Drain plug		1
	8913045T	Grease	1 kg	1
B	BR288	Motor connecting box		1
DC11	5434104K	Gear case	1 vitesse / speed	1
DC11	5444101B	Gear case	D	1
DC12	5434103J	Seal		1
DC12	5444103D	Seal	D	1
DC13	5434105L	Cover		1
DC13	5444105F	Cover	D	1
DC14	5444211W	Drive pinion - 16 teeth	D	1
DC14	5444215A	Drive pinion M3 - 11 teeth	Largeur de denture 45mm (->1989)/55mm(1989->)	1
DC16	300077	Interior circlip	D et DA - I/77 - Ø 47	1
DC17	7412045W	Bearing		1
DC17	7415050N	Bearing	D	1
DC17	7410055H	Bearing	D HPR 72 (Chariot / Trolley Bissel)	1
DC17	7464530V	Seal SIMRIT	D	1
DC19	5434201R	Gear - 93 teeth		1
DC19	5444201K	Gear - 136 teeth	D	1
DC20	7415040B	Bearing		1
DC20	7464510Y	Seal SIMRIT	20 ou 30 m/mn - 5-10 ou 20/5	1
DC21	7261042N	Interior circlip		1
DC22	830860	Exterior circlip - Ø 20	C2	1
DC23	5434203T	Sealing cap		1
DC31	5444501L	2 speed gearcase	D	1
DC31	5434501S	Gearcase 2 speeds		1
DC32	5434611L	Pinion shaft - 23 teeth		1
DC33	5434602B	Gear - 64 teeth	30/7.5 m/mn	1
DC33	5434601A	Gear - 69 teeth	5-10-20/5 m/mn	1
DC34	5434603C	Cover 42		1

DC141	7281082V	Key	D	1
DC141	7282062K	Pinion key - 23 teeth	2 BR 6x6x20	1
DC142	5444216B	Pinion collar - 11 teeth	DA	1
DC142	5444212X	Pinion collar - 16 teeth	D	1
DC142	5544212T	Pinion collar - 19 teeth	D - HPR 72 (chariot Bissel)	1
E36	5438101E	Motor pinion - 23 teeth	Alésage / Bore 14 - A,D	1
E361	5438111R	Collar pinion motor	A,D	1
M2	5543214H	Drive shaft - LHT	Hauteur Perdue Réduite / Low Headroom Trolley	1
M2	5543213G	Drive shaft - NHT	Hauteur Perdue Normale / Normal Headroom Trolley	1
M3	5543203W	Support tube - LHT	Hauteur Perdue Réduite / Low Headroom Trolley	1
M3	5533204C	Support tube - NHT	Hauteur Perdue Normale / Normal Headroom Trolley	1
M4	5433215U	Chain wheel	Tous types / All types	1
M5	820003	Galvanized hand chain - 5x27,1		1
M36	5543216K	Pinion - 11 teeth - NHT	Hauteur Perdue Normale / Normal Headroom Trolley	1
M361	5543215J	Pinion collar - 11 teeth - LHT	Hauteur Perdue Réduite / Low Headroom Trolley	1
M364	7281054Q	Key - NHT	Hauteur Perdue Normale / Normal Headroom Trolley	1
M	3543213U	Complete chaine drive - LHT	Hauteur Perdue Réduite / Low Headroom Trolley	1
M	3543212T	Complete chaine drive - NHT	Hauteur Perdue Normale / Normal Headroom Trolley	1

24) Hoist rope

En levage centré, prévoir les cosses en plus / In true vertical lift, don't forget additionnal rope fastener

item	reference	description	observation	Quantity
	<u>7312235G</u>	Non rotating cable - Ø11	mètre/meters	1
	<u>7312435Z</u>	Non rotating steel cable - Ø12	mètre/meters	1
	<u>7322435U</u>	Preformed cable - Ø12	mètre/meters	1
	<u>7322235B</u>	Preformed steel cable - Ø11	mètre/meters	1
	<u>7333120H</u>	Rope clamp - Ø12		1
	<u>7333100L</u>	Rope clip - ø 10		1

24.1) Precut rope

item	reference	description	observation	Quantity
	<u>5252215E</u>	Non rotating cable - Ø11	Lg 21,5m	1
	<u>5252217G</u>	Non rotating cable - Ø11	Lg 38m	1
	<u>53045007</u>	Non rotating cable - Ø11 16X7R-U-RHL-92.1	Lg 15,5 m	1
	<u>5252216F</u>	Non rotating cable - Ø11 RD 1/1 L - RD 2/1 HPR	Lg 37m	1
	<u>5252212B</u>	Non rotating cable - Ø11 RD 1/1 VL - RD 2/1 HPR	Lg 53m	1
	<u>5252214D</u>	Non rotating cable - Ø11 RD 1/1SVL - RD 2/1 HPR	Lg 65m	1
	<u>5252213C</u>	Non rotating cable - Ø11 RD 2/1 SVL	Lg 66m	1
	<u>5252211A</u>	Non rotating cable - Ø11 RD 2/1VL	Lg 54m	1
	<u>5352202L</u>	Non rotating cable - Ø12 2/1	Lg 37m	1
	<u>5352203N</u>	Non rotating cable - Ø12 2/1	Lg 38m	1
	<u>5352204P</u>	Non rotating cable - Ø12 2/1	Lg 53m	1
	<u>5352205Q</u>	Non rotating cable - Ø12 2/1	Lg 54m	1
	<u>5352206R</u>	Non rotating cable - Ø12 2/1	Lg 65m	1
	<u>5352201K</u>	Non rotating cable - Ø12 2/1	Lg 21,25m	1
	<u>5352207S</u>	Non rotating cable - Ø12 2/1	Lg 66m	1
	<u>5252202R</u>	Preformed cable - Ø11 RD 2/1 L - RD 4/1 HPR L	Lg 38m	1
	<u>5252201Q</u>	Preformed cable - Ø11 RD 2/1 N	Lg 22,25m	1
	<u>5252205U</u>	Preformed cable - Ø11 RD 4/1 HPR N	Lg 23m	1
	<u>5252206V</u>	Preformed cable - Ø11 RD 4/1 L	Lg 39m	1
	<u>5252204T</u>	Preformed cable - Ø11 RD 4/1 N	Lg 24,5m	1
	<u>5252221L</u>	Preformed cable - Ø11 RD 6/1 L	Lg 41,3m	1
	<u>5252220K</u>	Preformed cable - Ø11 RD 6/1 N	Lg 26,7m	1
	<u>5252223P</u>	Preformed cable - Ø11 RD 6/1 SVL	Lg 68,6m	1
	<u>5252222N</u>	Preformed cable - Ø11 RD 6/1 VL	Lg 59,4m	1
	<u>5252219J</u>	Preformed cable - Ø11 SVL -RD 4/1 HPR	Lg 65m	1
	<u>5252218H</u>	Preformed cable - Ø11 VL - RD 4/1 HPR	Lg 53m	1
	<u>S90B10L24T</u>	Preformed cable with rope fastener - Ø11 Before june 1971	Lg 24m	1
	<u>S90B10L25T</u>	Preformed cable with rope fastener - Ø11 Before june 1971	Lg 25m	1
	<u>S90B10L39T</u>	Preformed cable with rope fastener - Ø11 Before june 1971	Lg 39m	1
	<u>S90B10L40T</u>	Preformed cable with rope fastener - Ø11 Before june 1971	Lg 40m	1

25) Electrical equipment

item	reference	description	observation	Quantity
1	KP19D	Lightning sticker for cover		1
2	7514042N	Transformater 120VA 220/380V 48V		1
2	7516061G	Transformater 250VA 220/380V 2x24V		1
2	7511911W	Transformer 220/380V 2x24V (100VA)		1
2	7514041L	Transformer 220/380V	48V - 100VA	1
2	7511951Q	Transformer 240/415V 2x24V (100VA)		1
3	7532424T	Selection contactor LC1D408E		1
4	7536311T	Auxiliary contact LA1D11	N1 à N3	1
4	1113007	Auxiliary contact LA1D20	7536314W	1
4	7536312U	Auxiliary contact LA1D22	«2F+2O»	1
4	7536411B	Auxiliary contact LA2D22		1
4	7536413D	Auxiliary contact LA3D22		1
5	7571302B	Fuse 5x20 2A		1
5	7571303C	Fuse 5x20 3A		1
5	7571304D	Fuse 5x20 4A		1
6	7581401D	Hoisting motor terminal block		1
7	7691133C	Lamp	48V	1
8	7691142N	Bulb		1
9	3633515A	Single Protection phase	380V	1
10	3653510G	Electric circuit (3 relay)		1
11	3654511V	Control panel LVC L2 «C» 220V «DA» 380V4Kw		1
12	7521111W	Rectifier	Frein / Brake 24V	1
12	7521122H	Rectifier	Frein / Brake 48V	1
13	5651311E	Diode rectifier G6004		1
14	7523111V	Condenser 25mF 63V - Old hoist		1
15	1113021	Selector contactor	48V	1
15	1113027	Two speed selection contactor 400V/48V - LC1D128E	(7532122Q) - AK4 - Moteur /Motor P1,P2,P3	1
15	1113029	Two speed selection contactor 400V/48V - LC1D258E	(7532324J) - AK4 - Moteur/Motor P4/P5	1
16	7532326L	Contacteur ON-OFF	LC1D253E	1
16	7532126U	Main contactor 400V-48V	LC1D123E	1
16	7532426V	Main contactor - 400V/ 48V - LC1D403E7	Moteur / Motor P6 - O-K1	1
17	1113025	Interlocked contactor LC2EC09E	7531023V	1
17	7531122C	Interlocked contactors 400V/48V - LC2D129E	AK1-AK2 - Moteur/Motor P1-P2-P3-N1-N2	1
17	7531423E	Up and down contactor 400V/48V - LC2D403E	Moteur / Motor P7 - AK1-AK2	1