

## **Spare parts catalog for "VL02-VL05-XC1"**

To avoid errors, when ordering please specify:

- Complete type of hoist
- Date of manufacture and serial number
- Spare part code
- Spare part designation
- Additional information

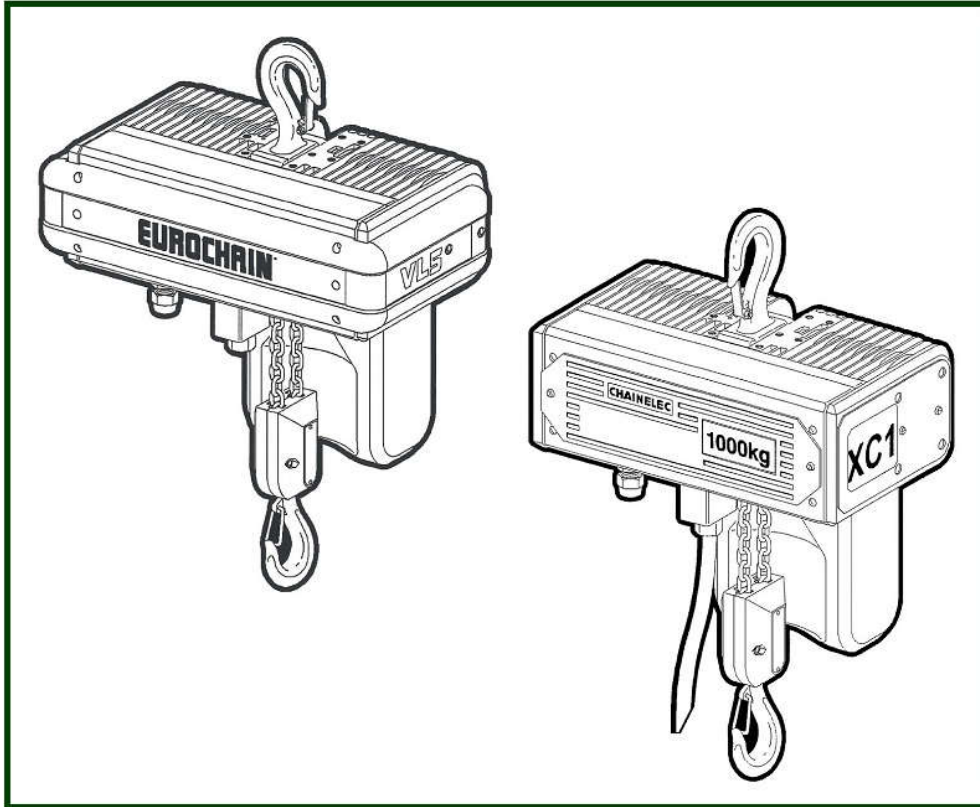

### 0) COMMENTS

1) HOIST MOTOR AND CASING - VERSION 1

2) HOIST MOTOR AND CASING - VERSION 2

3) MECHANISM / BRAKE - VERSION 1

4) MECHANISM / BRAKE - VERSION 2

5) LIFTING ASSEMBLY

5.1) Version 1

5.2) Version 2

5.3) Pre cut chain

6) ELECTRIC BOX

7) UPPER AND LOWER LIMIT SWITCH - OPTION

8) CAM OPERATED LIMIT SWITCH - OPTION

9) SPECIFICS PARTS - DOUBLE BRAKES

## 0) Comments

Pour les numéros de série commençant par 98 : nous consulter / for serial numbers beginning with 98 : please consult us

CAPACITE DE CHARGE	TYPE DE PALAN	OBSERVATIONS(voir repères)	NOMBRE DE BRINS	TYPE DE CHAINE
LOAD CAPACITY	TYPE OF HOIST	OBSERVATIONS(SEE MARKS)	NUMBER OF FALLS	TYPE OF CHAIN
125 Kg	VL2 124 m2		1	4.8*12.5
	VL2 128 m2			
	VL2 128 b2			
	VL2 1216 b2			
250 Kg	VL2 254 m1		2	
	VL2 258 m1			
	VL2 258 b1			
	VL5 2516 b1		1	
	VL5 254 m2			
	VL5 258 m2			
	VL5 258 b2			
500 Kg	VL2 504 m1		2	
	VL5 504 m1		1	
	VL2 504 b1		2	
	VL5 508 m1		1	
	VL5 508 b1			
	VL5 504 m2		2	
	VL5 504 b2			
1000 Kg	VL5 1004 m1		2	
	VL5 1004 b1			

# 1) Hoist motor and casing - Version 1

Les numéros de série commençant par 96/97 : version 1 / serial number beginning with 96 or 97 : version 1

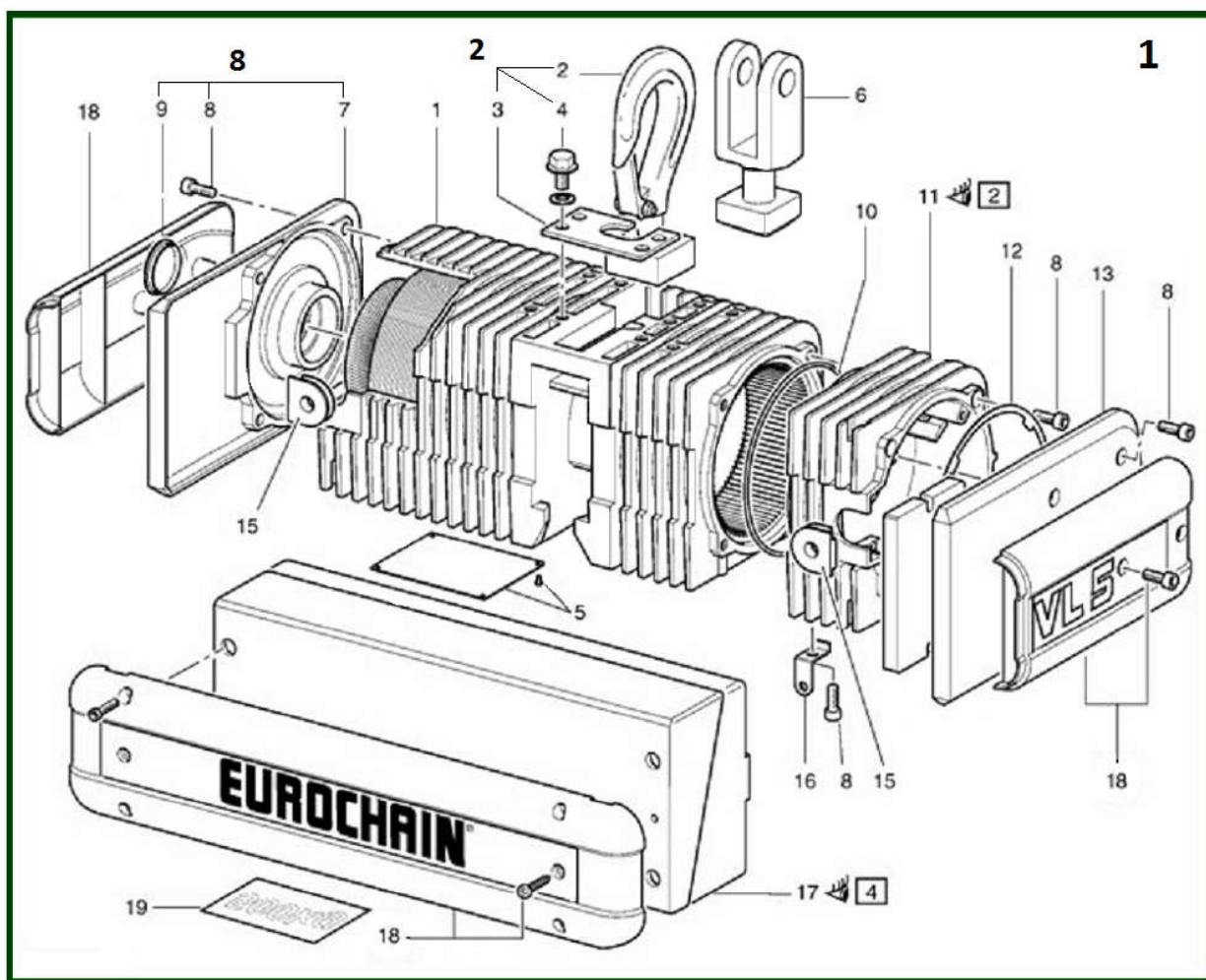

item	reference	description	observation	Quantity
1	<u>NCCASC</u>	Casing assembled with stator and gear rim		1
2	<u>2219900</u>	Hook suspension set	2+3+4	1
5	<u>2216520</u>	Motor data plate	N° de série obligatoire / Only if serial number provided	1
6	<u>2229917</u>	Trolley coupling set	6+3+4	1
8	<u>2219961</u>	Motor end cap assembly	Vis M6 + Opercule de fermeture / M6 screw + Cap	1
10	<u>8380202</u>	O ring		1
11	<u>2210011</u>	Brake endcap	Plus fourni / Not supplied anymore	0
12	<u>2218002</u>	Sealing ring set	Plus fourni / Not supplied anymore	0
13	<u>2219962</u>	Brake end cap assembly		1
15	<u>2218004</u>	Grommet		2
16	<u>2218000</u>	Push button station fixing point		1
17	<u>2219993</u>	Electric cubicle (lid, cover, ground terminal and screws) -	ABS	1
17	<u>2219934</u>	Electric cubicle (lid, cover, ground terminal and screws) -	Noryl (CSA)	1
18	<u>2216051</u>	Marking & covers set	VLE5	1
18	<u>2216061</u>	Stickers and covers	VLE2	1
19	<u>2219920</u>	Set of 10 load plates	500 Kg	1
19	<u>2219921</u>	Set of 10 load plates	630 Kg	1
19	<u>2219922</u>	Set of 10 load plates	1000 Kg	1
19	<u>2219938</u>	Set of 10 load plates	125 kg	1
19	<u>2219917</u>	Set of 10 load plates	160 kg	1
19	<u>2219918</u>	Set of 10 load plates	250 kg	1
19	<u>2219919</u>	Set of 10 load plates	320 kg	1
-	<u>NCS</u>	Stator - 1 speed - 4 poles		1



3b	<u>2229920</u>	Crosshead set + shaft and screws	Suspension parallèle : CHM - Suspension perpendiculaire : CHR Parallel suspension : CHM - Perpendicular mounting : CHR	1
4	<u>2219961</u>	Motor end cap assembly	Vis M6 + Opercule de fermeture / M6 screw + Cap	1
5	<u>2219962</u>	Brake end cap assembly		1
6	<u>2210007</u>	Brake cap assembly		1
7	<u>2218000</u>	Push button station fixing point		1
8	<u>2216051</u>	Marking & covers set	VL5	1
8	<u>2216053</u>	Marking & covers set	XC1	1
8	<u>2216061</u>	Stickers and covers	VL2	1
8	<u>52328143</u>	Stickers and covers	XC1 RNUR	1
9	<u>2218004</u>	Grommet		1
10	<u>2218006</u>	Sealing ring and O-ring for brake cap		1
11	<u>2216520</u>	Motor data plate	N° de série obligatoire / Only if serial number provided	1
12	<u>2219920</u>	Set of 10 load plates	500 Kg	1
12	<u>2219921</u>	Set of 10 load plates	630 Kg	1
12	<u>2219922</u>	Set of 10 load plates	1000 Kg	1
12	<u>2219938</u>	Set of 10 load plates	125 kg	1
12	<u>2219917</u>	Set of 10 load plates	160 kg	1
12	<u>2219918</u>	Set of 10 load plates	250 kg	1
12	<u>2219919</u>	Set of 10 load plates	320 kg	1
13	<u>2219550</u>	Rain cover		1
14	<u>52308744</u>	Cap - Brake side		1
-	<u>52296262</u>	Stator - 2 speeds	P7/380V-415V 50H 18/3K	1
-	<u>NCMMV</u>	Stators - 1 speed	4P	1

### 3) Mechanism / Brake - Version 1

Les numéros de série commençant par 96/97 : version 1 / serial number beginning with 96 or 97 : version 1

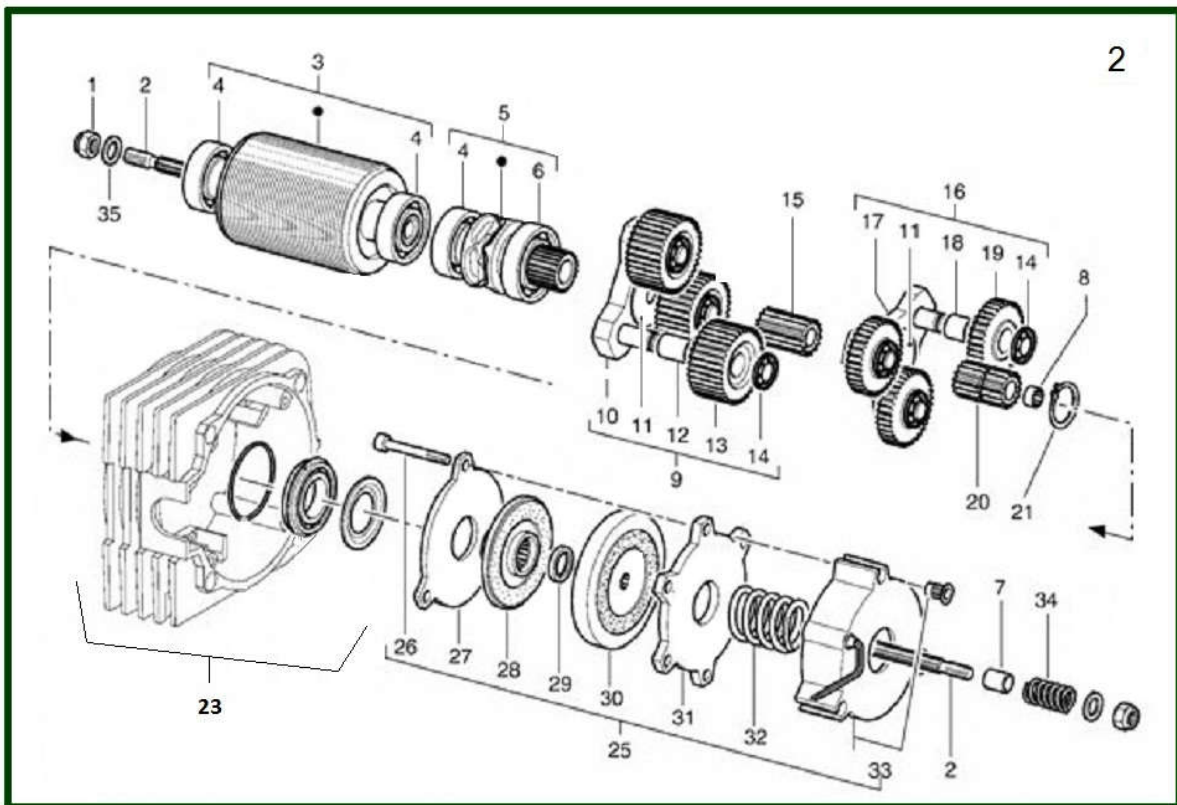

item	reference	description	observation	Quantity
2	<a href="#">2211500</a>	Gear input shaft		1
3	<a href="#">2215000</a>	Rotor assembly	. +4+4 - Bi vitesses / 2 speeds	1
3	<a href="#">2215001</a>	Rotor assembly	. +4+4 - Mono vitesse / 1 speed	1
5	<a href="#">2214001</a>	Chain sprocket assembled	. +4+6	1
9	<a href="#">2210520</a>	Planet gear assembly - 2nd step	10+11+12+13+14 - 16 m/min	1
9	<a href="#">2210500</a>	Planet gear assembly - 2nd step	10+11+12+13+14 8 m/min	1
15-20	<a href="#">2210503</a>	Pinion	Item 15 : 2è étage / 2nd step	1
23	<a href="#">2219982</a>	Metal sealing ring set		1
25	<a href="#">2211012</a>	Brake limiter, assembly - 100V	De 220 V à 230 V	1
25	<a href="#">2211000</a>	Brake limiter, assembly - 190V	De 380 V à 460 V	1
25	<a href="#">2211013</a>	Brake limiter, assembly - 240V	De 500 V à 575 V	1
34	<a href="#">2211016</a>	Clutch spring set		1

## 4) Mechanism / Brake - Version 2

Les palans entre 1999 et 2003 : version 2 / Hoists between 1999 and 2003 : version 2

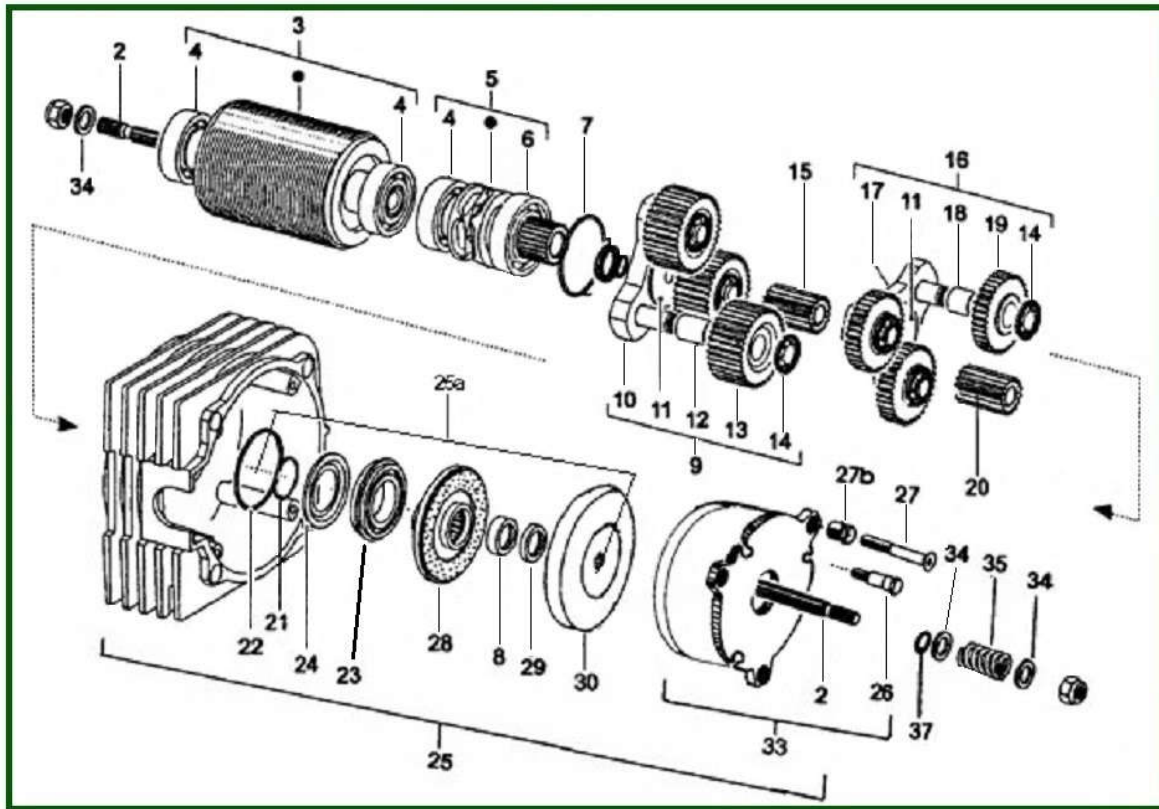

item	reference	description	observation	Quantity
2	<a href="#">2211501</a>	Gear input shaft		1
3	<a href="#">2215000</a>	Rotor assembly	. +4+4 - Bi vitesse / 2 speeds	1
3	<a href="#">2215001</a>	Rotor assembly	. +4+4 - Mono vitesse / 1 speed	1
4	<a href="#">833713</a>	Bearing		1
5	<a href="#">2214001</a>	Chain sprocket assembled	. +4+6	1
9	<a href="#">2210520</a>	Planet gear assembly - 2nd step	10+11+12+13+14 - 16 m/min	1
9	<a href="#">2210500</a>	Planet gear assembly - 2nd step	10+11+12+13+14 8 m/min	1
15-20	<a href="#">2210503</a>	Pinion	Item 15 : 2è étage / 2nd step	1
16	<a href="#">2210510</a>	Planet gear assembly - 1st step	11+14+17+18+9	1
25	<a href="#">2211071</a>	Brake limiter, assembly + housing 100 VDC	De 220 V 230V	0
25	<a href="#">2211070</a>	Brake limiter, assembly + housing 190 VDC	De 380 V 460 V	0
25	<a href="#">2211072</a>	Brake limiter, assembly + housing 240 VDC	De 500 V 575 V	0
25a	<a href="#">2219984</a>	Metal sealing ring set and brake disc	21+22+23+ 24+28+8+29+30	1
30	<a href="#">2211020</a>	Brake disk		1
33	<a href="#">2211080</a>	Brake with fittings	100 V	1
33	<a href="#">2211081</a>	Brake with fittings	190 V	1
33	<a href="#">2211082</a>	Brake with fittings	240 V	1
-	<a href="#">2211016</a>	Clutch spring set		1
-	<a href="#">2219983</a>	Gear sealing set		1
-	<a href="#">2218009</a>	Sealing set	22+23+24+29+37	1





## 5.1) Version 1

Les numéros de série commençant par 96/97 : version 1 / serial number beginning with 96 or 97 : version 1

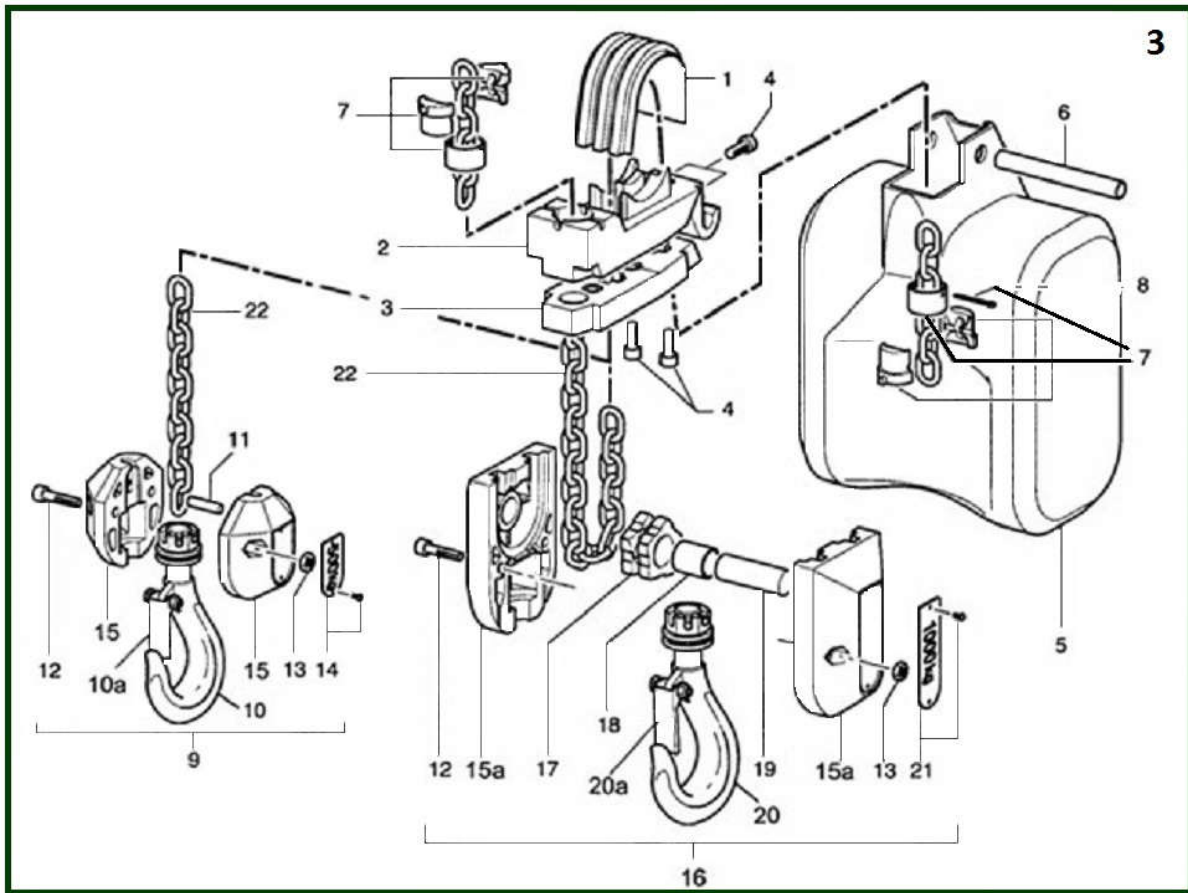

item	reference	description	observation	Quantity
1	<a href="#">2214006</a>	Upper chain guide		1
2 + 3	<a href="#">2214010</a>	Set of lower chain guide + Rubber buffer		1
3	<a href="#">2214009</a>	Rubber buffer set		1
5	<a href="#">2219925</a>	Chain bag	8 m	1
5	<a href="#">2219926</a>	Chain bag	16 m - remplacé par B à C 50m / replaced by chain bag 50m	1
5	<a href="#">2219927</a>	Chain bag	30 m - remplacé par B à C 50m / replaced by chain bag 50m	1
5	<a href="#">2219928</a>	Chain bag	50 m	1
6	<a href="#">2211048</a>	Suspension shaft	Diam = 10 mm	1
9	<a href="#">2219902</a>	Lower hook block assembly	1 brin / 1 fall - Court/Short-Long	1
9	<a href="#">2212018</a>	Lower hook block assembly - Self locking type	1 brin / 1 fall	1
10	<a href="#">2217015</a>	Lifting hook - Self locking type	1 brin / 1 fall - 2 brins / 2 falls	1
10	<a href="#">2212011</a>	Lifting hook - Standard	1 brin / 1 fall	1
10a	<a href="#">2212016</a>	Safety latch - Steel	Crochet supérieur - 1brin / Upper hook - 1 fall	1
10a	<a href="#">A001512</a>	Safety latch - Steel wire type	1 brin / 1 fall-2 brins / 2 falls PHR - 500 kg	1
14	<a href="#">2219937</a>	Set of 10 load plates - 1 fall	125 kg	1
14	<a href="#">2219906</a>	Set of 10 load plates - 1 fall	160 kg	2
14	<a href="#">2219907</a>	Set of 10 load plates - 1 fall	250 kg	2
14	<a href="#">2219908</a>	Set of 10 load plates - 1 fall	320 kg	2
14	<a href="#">2219909</a>	Set of 10 load plates - 1 fall	500 kg	1
16	<a href="#">2212028</a>	Hook block - Self locking type	2 brins / 2 falls	1
16	<a href="#">2212020</a>	Hook block - Standard type	2 brins / 2 falls	1
17	<a href="#">2219986</a>	Idler sprocket kit		1
20	<a href="#">2247015</a>	Lifting hook block - Self-locking type	C06 : 2 Brins / falls C10 : 1 Brin / fall	1
20	<a href="#">2217004</a>	Lifting hook - Standard type	1 brin / 1 fall	1
20a	<a href="#">2212017</a>	Safety latch - Steel plate type	1 & 2 brins - Depuis 2000 - 025T 1 & 2 falls - Since 2000 - 025T	1

20a	<u>A001515</u>	Safety latch - Steel wire type 025 or 012	PHR : 1000 kg - 2 brins / falls	1
21a	<u>2219910</u>	Set of 10 load plates - 2 falls	320 kg	1
21b	<u>2219911</u>	Set of 10 load plates - 2 falls	500 kg	1
21c	<u>2219912</u>	Set of 10 load plates - 2 falls	630 kg	1
21d	<u>2219913</u>	Set of 10 load plates - 2 falls	1000 kg	1
22	<u>2213501V</u>	Black load chain - 4.8x12.5		1
22	<u>2213503V</u>	Chain - 4.8x12.5	H80C	1
22	<u>2213500V</u>	Galvanized load chain4.8x12.5		1
22	<u>2213502V</u>	Stainless steel chain - 4.8x12.5	Attention la capacité de charge / Be careful at load capacity	1
24	<u>2213523</u>	Chain anchor assembly		1
-	<u>9995005</u>	Can of oil for chain for chain	125 ml	1
-	<u>2211045</u>	Load chain mounting tool		1
-	<u>2219987</u>	Set of 2 half-casings, axle, return sprocket, and screws		1
-	<u>2219985</u>	Set of 2 half-casings with axle and screws		1
-	<u>2211050</u>	Slack fall stop assembly		1

## 5.2) Version 2

Les palans entre 1999 et 2003 : version 2 / Hoists between 1999 and 2003 : version 2

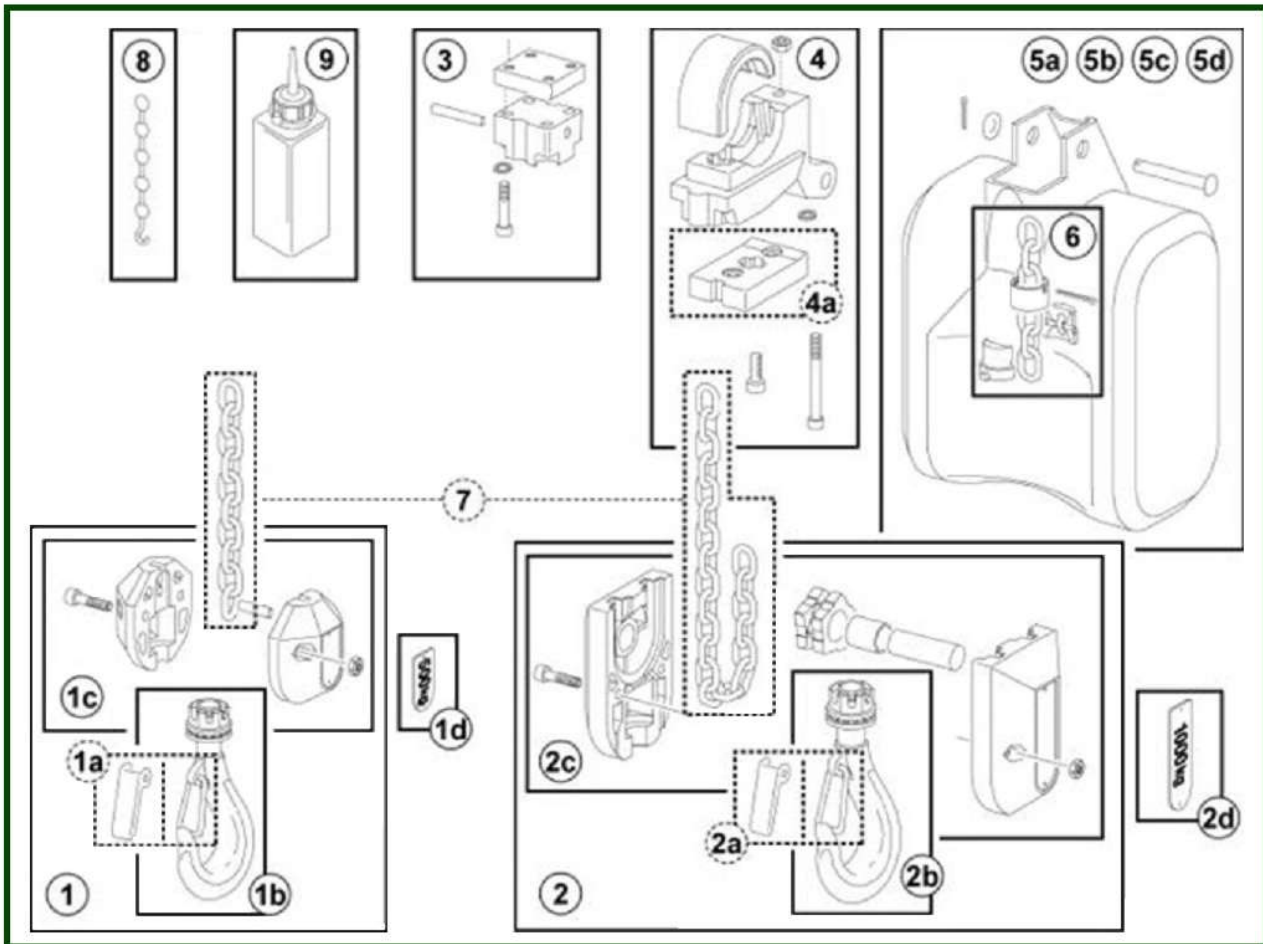

item	reference	description	observation	Quantity
1	<a href="#">2219902</a>	Lower hook block assembly	1 brin / 1 fall - Court/Short-Long	1
1	<a href="#">2212018</a>	Lower hook block assembly - Self locking type	1 brin / 1 fall	1
1a	<a href="#">2212016</a>	Safety latch - Steel	Crochet supérieur - 1brin / Upper hook - 1 fall	1
1a	<a href="#">A001512</a>	Safety latch - Steel wire type	1 brin / 1 fall-2 brins / 2 falls PHR - 500 kg	1
1b	<a href="#">2217015</a>	Lifting hook - Self locking type	1 brin / 1 fall - 2 brins / 2 falls	1
1b	<a href="#">2212011</a>	Lifting hook - Standard	1 brin/ 1 fall	1
1c	<a href="#">2219985</a>	Set of 2 half-casings with axle and screws		1
1d	<a href="#">2219937</a>	Set of 10 load plates - 1 fall	125 kg	1
1d	<a href="#">2219906</a>	Set of 10 load plates - 1 fall	160 kg	1
1d	<a href="#">2219907</a>	Set of 10 load plates - 1 fall	250 kg	1
1d	<a href="#">2219908</a>	Set of 10 load plates - 1 fall	320 kg	1
1d	<a href="#">2219909</a>	Set of 10 load plates - 1 fall	500 kg	1
2	<a href="#">2212028</a>	Hook block - Self locking type	2 brins / 2 falls	1
2	<a href="#">2212020</a>	Hook block - Standard type	2 brins / 2 falls	1
2a	<a href="#">2212017</a>	Safety latch - Steel plate type	1 & 2 brins - Depuis 2000 - 025T 1 & 2 falls - Since 2000 - 025T	1
2a	<a href="#">A001515</a>	Safety latch - Steel wire type 025 or 012	PHR : 1000 kg - 2 brins / falls	1
2b	<a href="#">2247015</a>	Lifting hook block - Self-locking type	C06 : 2 Brins / falls C10 : 1 Brin / fall	1
2b	<a href="#">2217004</a>	Lifting hook - Standard type	1 brin / 1 fall	1
2c	<a href="#">2219987</a>	Set of 2 half-casings, axle, return sprocket, and screws		1
2d	<a href="#">2219910</a>	Set of 10 load plates - 2 falls	320 kg	1
2d	<a href="#">2219911</a>	Set of 10 load plates - 2 falls	500 kg	1
2d	<a href="#">2219912</a>	Set of 10 load plates - 2 falls	630 kg	1
2d	<a href="#">2219913</a>	Set of 10 load plates - 2 falls	1000 kg	1

3	<u>2213523</u>	Chain anchor assembly		1
4	<u>2214004</u>	Upper and lower chain guide assembly with rubber buffer		1
4a	<u>2214013</u>	Rubber buffer		1
5a	<u>2219990</u>	Chain bag	8 m	1
5b	<u>2249925</u>	Chain bag	C05 : 16 m - C10 : 8 m	1
5c	<u>2249926</u>	Chain bag	C05 : 30 m - C10 : 16 m	1
5d	<u>2249932</u>	Chain bag	C05 : 50 m - C10 : 30 m	1
6	<u>2211050</u>	Slack fall stop assembly		1
7	<u>2213501V</u>	Black load chain - 4.8x12.5		1
7	<u>2213503V</u>	Chain - 4.8x12.5	H80C	1
7	<u>2213500V</u>	Galvanized load chain4.8x12.5		1
7	<u>2213502V</u>	Stainless steel chain - 4.8x12.5	Attention à la capacité de charge / Be careful at load capacity	1
8	<u>2211045</u>	Load chain mounting tool		1
9	<u>9995008</u>	Oil can	125 ml	1
-	<u>2219986</u>	Idler sprocket kit		1

### **5.3) Precut chain**

<b>item</b>	<b>reference</b>	<b>description</b>	<b>observation</b>	<b>Quantity</b>
	<u>53019851</u>	Black load chain - 4.8x12.5	15 mètres / meters	1
	<u>53019860</u>	Black load chain - 4.8x12.5	18 mètres / meters	1
	<u>53019865</u>	Black load chain - 4.8x12.5	20,5 mètres / meters	1
	<u>53019862</u>	Black load chain - 4.8x12.5	20 mètres / meters	1
	<u>53019870</u>	Black load chain - 4.8x12.5	21 mètres / meters	1
	<u>53019875</u>	Black load chain - 4.8x12.5	25 mètres / meters	1
	<u>53019876</u>	Black load chain - 4.8x12.5	26 mètres / meters	1
	<u>53019877</u>	Black load chain - 4.8x12.5	100 mètres / meters	1
	<u>53019943</u>	Galvanized load chain - 4.8x12.5	8 mètres / meters	1
	<u>53019945</u>	Galvanized load chain - 4.8x12.5	9 mètres / meters	1
	<u>53019949</u>	Galvanized load chain - 4.8x12.5	10 mètres / meters	1
	<u>53019956</u>	Galvanized load chain - 4.8x12.5	11 mètres / meters	1
	<u>53019958</u>	Galvanized load chain - 4.8x12.5	12 mètres / meters	1
	<u>53019924</u>	Galvanized load chain - 4.8x12.5	3,2 mètres / meters	1
	<u>53019930</u>	Galvanized load chain - 4.8x12.5	4 mètres / meters	1
	<u>53019932</u>	Galvanized load chain - 4.8x12.5	5 mètres / meters	1
	<u>53019937</u>	Galvanized load chain - 4.8x12.5	6 mètres / meters	1
	<u>53019938</u>	Galvanized load chain - 4.8x12.5	7 mètres / meters	1

## 6) Electric box

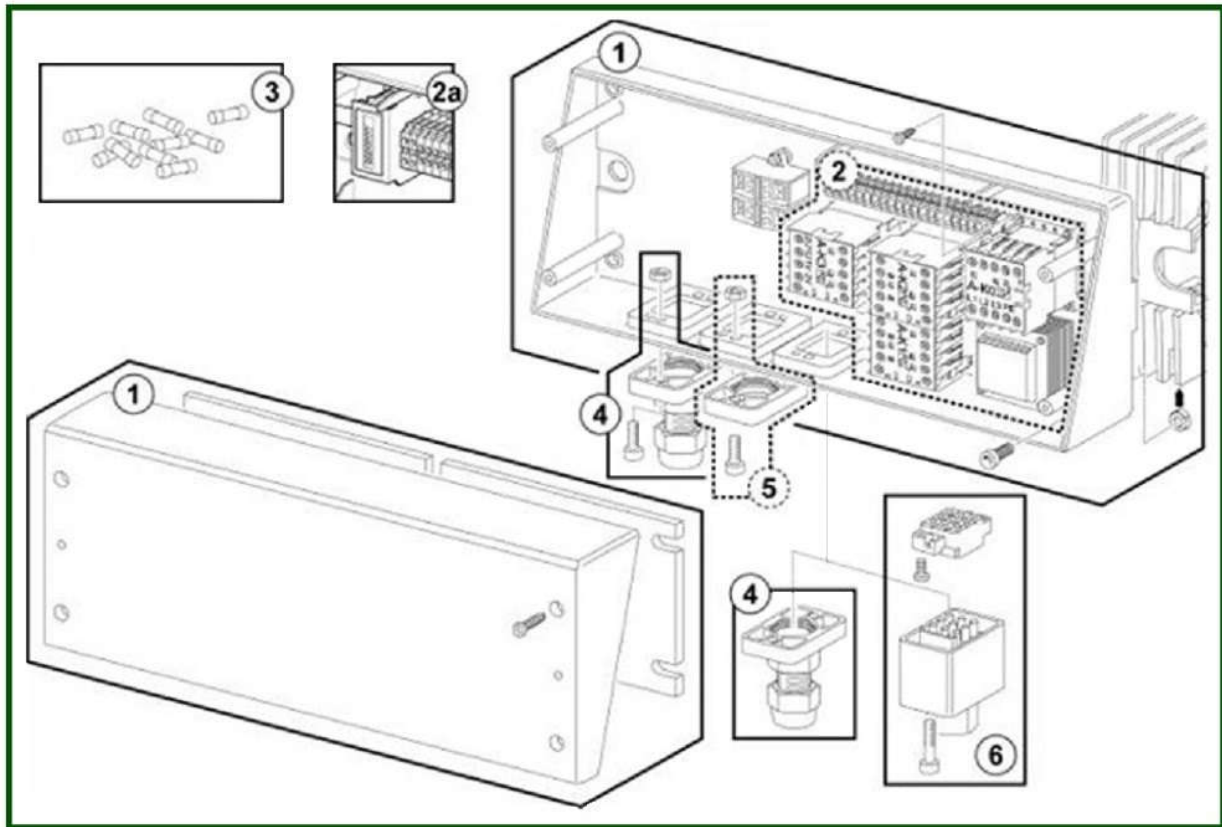

item	reference	description	observation	Quantity
1	<a href="#">7383020</a>	Earth		1
1	<a href="#">2219993</a>	Electric cubicle (lid, cover, ground terminal and screws) -	ABS	1
1	<a href="#">2219934</a>	Electric cubicle (lid, cover, ground terminal and screws) -	Noryl (CSA)	1
1	<a href="#">2219957</a>	Electric cubicle base		1
1	<a href="#">2219963</a>	Electric cubicle base	Noryl (CSA)	1
1	<a href="#">2219956</a>	Electric cubicle cover e tuiped		1
1	<a href="#">2213001</a>	Electric cubicle cover e tuiped	Noryl (CSA)	1
2	<a href="#">833098</a>	Brake control module - Main switching control type	230 & 400 V Coffret acier auto/Steel cubicle automotive	1
2	<a href="#">833096</a>	Brake control module - Main switching control type	500 V Palan type E seulement/ E type hoist only	1
2	<a href="#">2133033</a>	CI board	2VD/2CS MAC	1
2	<a href="#">2213003</a>	CI board	2VL+MA / 2HS+ON/OFF - 230V - 50Hz 60Hz - 48VAC	1
2	<a href="#">2213005</a>	CI board	2VL+MA / 2HS+ON/OFF - 400V - 50Hz 60Hz - 24VAC	1
2	<a href="#">2213004</a>	CI board	2VL+MA / 2HS+ON/OFF - 400V - 50Hz 60Hz - 48VAC	1
2	<a href="#">2213025</a>	PC board	2VL+MA / 2HS+ON/OFF - 400V - 50Hz 60Hz - 115VAC	1
2	<a href="#">2213013</a>	PC board	2VL+MA / 2HS+ON/OFF - 460V - 50Hz 60Hz - 48VAC	1
2	<a href="#">2213014</a>	PC board	2VL+MA / 2HS+ON/OFF - 460V - 60Hz - 115VAC	1
2	<a href="#">2213011</a>	PC board	2VL+MA / 2HS+ON/OFF - 500V - 50Hz 60Hz - 48VAC	1
2	<a href="#">2213012</a>	PC board	2VL+MA / 2HS+ON/OFF - 575V - 50Hz 60Hz - 48VAC	1
2	<a href="#">2213037</a>	PC board	2VL+MA / 2HS+ON/OFF - 690V - 50Hz 60Hz - 48VAC	1
2	<a href="#">2213015</a>	PC board		1
2	<a href="#">2213018</a>	PC board - Reconnectable	230V 460V - 60Hz - 115VAC	1
2	<a href="#">2213017</a>	PC board - Standard	230V 460V - 60Hz - 115VAC	1
2a	<a href="#">2213027</a>	Hour counter	60Hz 48VAC	1
2a	<a href="#">2213028</a>	Hour counter	60Hz 115VAC	1
2a	<a href="#">2213002</a>	Hour counter	50Hz 48VAC	1
3	<a href="#">2219988</a>	Set of 10 fuses		1
4	<a href="#">2249947</a>	Cable gland assembly		1

5	<u>2219814</u>	Closing plate assembly		1
6	<u>2249945</u>	Connecting plug set for push-button box	M+F Standard	1
6	<u>2249946</u>	Connecting plug set for trolley	TDU - M+F Standard	1
6	<u>2249982</u>	power supply plug		1
7	<u>2249898</u>	Set of pendant plug + electric cable connected	5 m - 8x1,5mm	1
7	<u>2249899</u>	Set of pendant plug + electric cable connected	10 m - 8x1,5mm	1
8	<u>7983002</u>	PCB Transformer	230V - 50Hz 60Hz - 48V	1
8	<u>7983001</u>	PCB Transformer	400V - 48V	1
8	<u>7983003</u>	PCB Transformer	500V - 48V	1

## 7) Upper and lower limit switch - Option

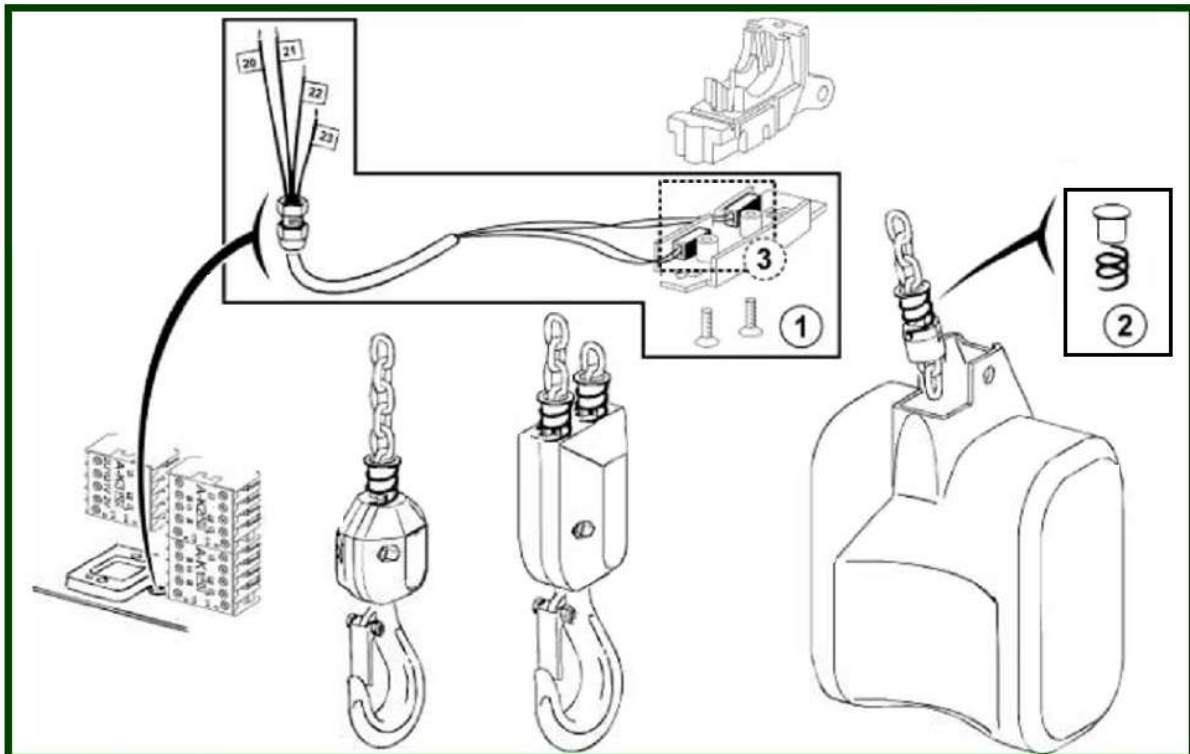

### Montage / Assembly

La butée de fin de course haut et bas se monte à la place de la butée caoutchouc (rep. 4a).

The limit switch is mounted in the place of the rubber buffer (rep. 4a)

Les vis CHc sont remplacées par des vis F90 M 6x30.

The CHc screws are replaced by F90 M 6x30 screws.

Perçer le coffret électrique d'un trou Ø 16mm, suivant les côtes indiquées sur le dessin.

Drill the hole for the cable gland (PG) to the electric cubicle according to the drawing.

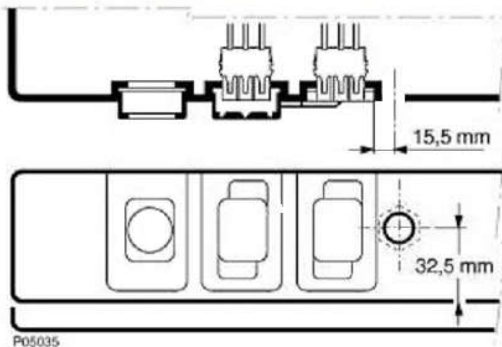

### ATTENTION !

Débrancher l'alimentation électrique avant toute intervention sur le coffret.

Cut off the mains power supply before doing any work on the electric cubicle.

Prendre garde de ne pas détériorer un élément de la platine pendant le perçage.

Take care not to damage any electrical components when drilling.

Placer le presse-étoupe, la tête hexagonale de celui-ci doit être bloquée par le bord de l'empreinte de prise encliquetable.

Insert the PG into the hole you have drilled, the side of the nut should be against the side of the nearby fast plug connector to avoid the nut's turning when tightening.

Faire passer les fils électriques par le presse-étoupe et suivre les indications portées sur ceux-ci pour les brancher aux bornes de la platine, à la place des shunts.

Pass the cables through the PG and follow the markings on them to connect the cables to the shunt on the PCB board

20 - 21 : Fin de course haut

Upper Limit

22 - 23 : Fin de course bas

Lower Limit

item	reference	description	observation	Quantity
1	<a href="#">2213041</a>	Micro-switches assembly		1
2	<a href="#">2213042</a>	Spring assembly + support		1
3	<a href="#">7291040</a>	Micro-switch - CSA type	Avant/Before 12/2005	1
3	<a href="#">7291030</a>	Micro-switch - Standard type	Avant/Before 12/2005	1
-	<a href="#">2213050</a>	Complete limit switch device		1



## 8) Cam operated limit switch - Option

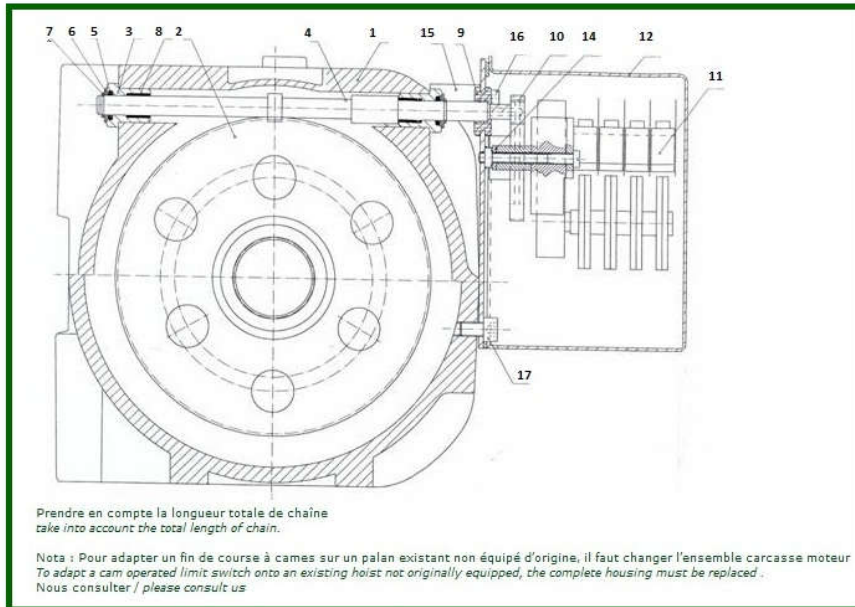

item	reference	description	observation	Quantity
1	<a href="#">2249076</a>	2 cam limit switch 0 to 10m	10+11+14	1
1	<a href="#">2249078</a>	2 cam limit switch 10m	10+11+14	1
1	<a href="#">2249077</a>	4 cam limit switch 0 to 10m	10+11+14	1
1	<a href="#">2249079</a>	4 cam limit switch 10m	10+11+14	1
2	<a href="#">2219006</a>	Planet Gear support		1
10	<a href="#">2249075</a>	Pinion - 24 teeth		1
-	<a href="#">52304656</a>	Bush assembly	8+3	1
-	<a href="#">2219045</a>	Enclosure assembly		1
-	<a href="#">52304654</a>	Shaft assembly	4+5+6+7	1

## 9) Specifics parts - Double brakes

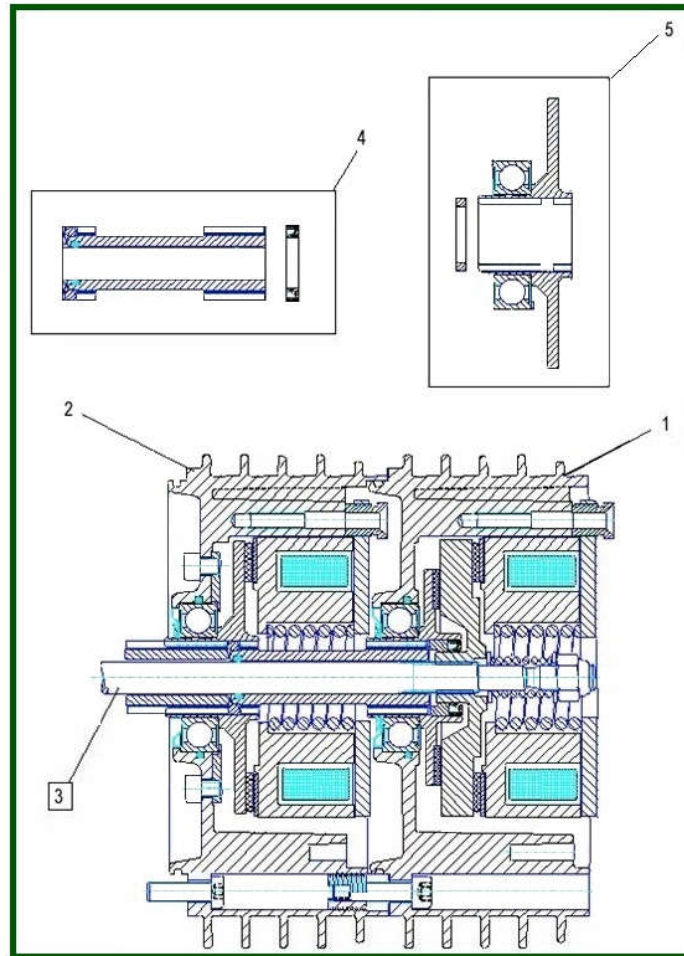

item	reference	description	observation	Quantity
1	<a href="#">2219017</a>	first brake limiter assembly with housing	100VDC	1
1	<a href="#">2219007</a>	first brake limiter assembly with housing	190VDC	1
2	<a href="#">2219008</a>	first brake limiter assembly with housing	190VDC	1
2	<a href="#">2219018</a>	Second brake assembly with housing	100VDC	1
3	<a href="#">2219051</a>	Double brake motor shaft		1
4	<a href="#">52316873</a>	Coupling pinion set		1
5	<a href="#">52316872</a>	friction disc assembly for second brake		1
6	<a href="#">52316874</a>	Sealing set		1
7	<a href="#">2219058</a>	Metal electric box		1